

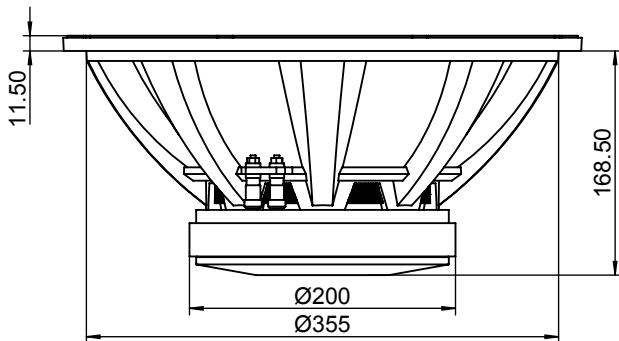

15" Professional Woofer 8 Ohm

ODEUM Apollo 15LF

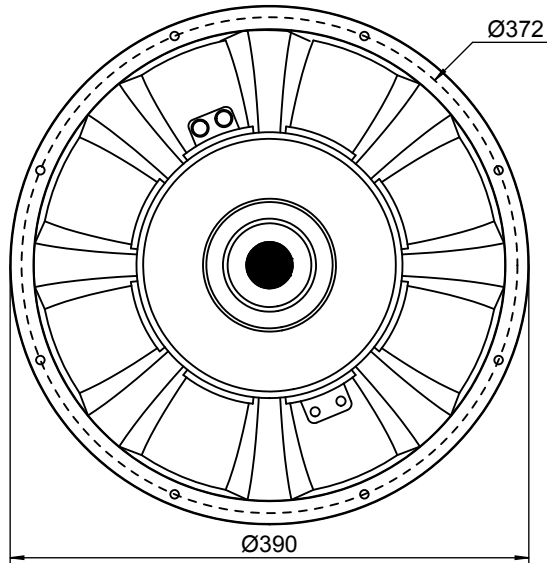

PARAMETERS

Impedance	8 ohms
Re	6.4 ohms
Le	1.74 mH @ 1kHz
Fs	25.5 Hz
Qms	6.70
Qes	0.27
Qts	0.26
Mms	117g
Cms	0.33 mm/N
Sd	837.4 cm ²
Vd	774.6 cm ³
BL	21.1 Tm
Vas	331.3 liters
Xmax	9.25 mm*
Magnetic Gap Height	9.5 mm
VC Diameter	78 mm
VC Winding Height	28 mm
SPL	96 dB @ 2.83V/1m
RMS Power Handling (AES 426B)	700 watts
Usable Frequency Range (Hz)	25 - 1,200 Hz

$$* X_{max} = \frac{VC \text{ Winding Height} - \text{Magnetic Gap Height}}{2}$$

FEATURES

- Powerful Y35 grade ferrite motor for increased control and efficiency
- Raised pole piece for a more symmetrical B1 field
- Treated paper cone for strength and durability in the elements
- Progressive-roll spider for better cone control under high excursions
- Inside-outside wound 3" voice coil on fiberglass former lends solid power handling capability
- Excessive venting for reduced power compression
- Over 9mm linear one-way Xmax for increased output at lower frequencies

IMPEDANCE/PHASE

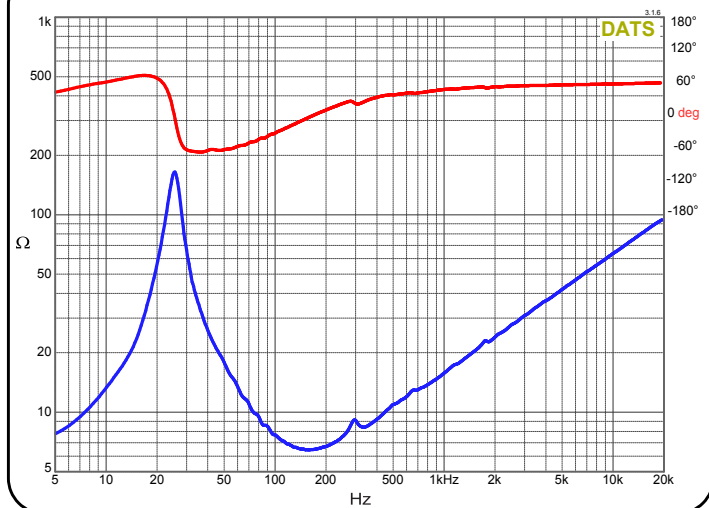

FREQUENCY RESPONSE

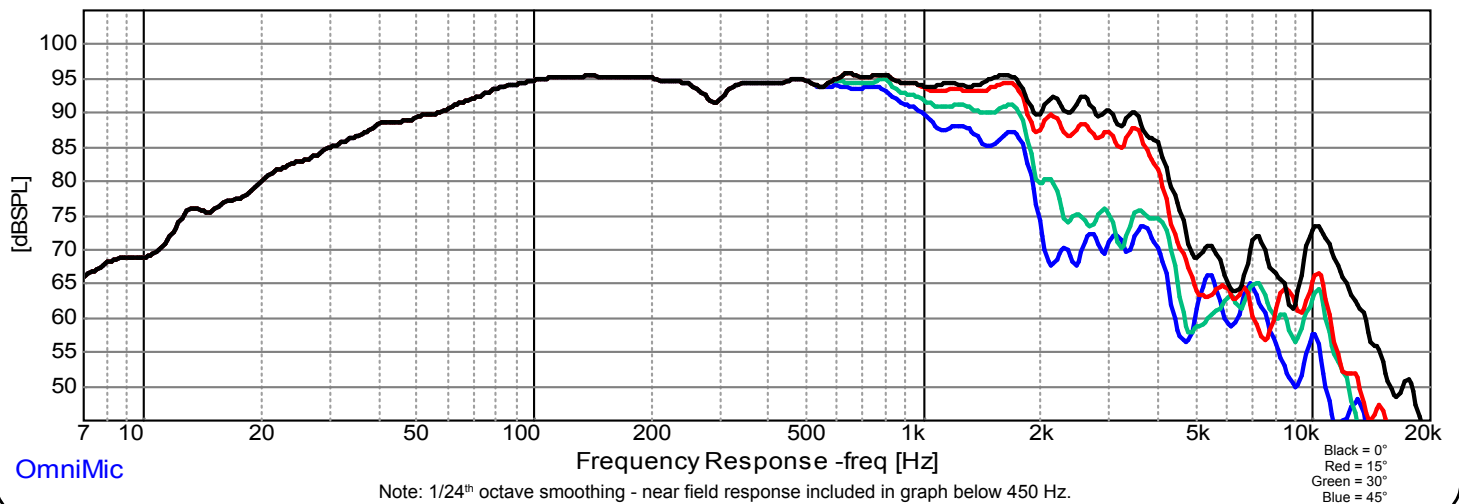

Note: 1/24th octave smoothing - near field response included in graph below 450 Hz.

OmniMic

Black = 0°
Red = 15°
Green = 30°
Blue = 45°