

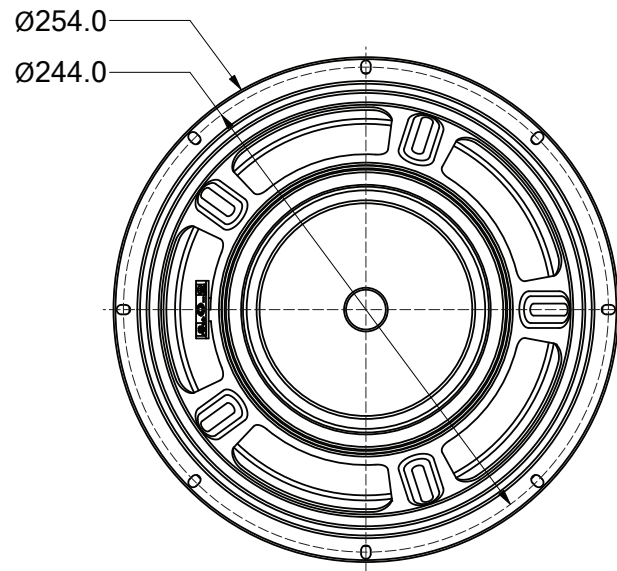

A25-10 REPLACEMENT 10" WOOFER FOR DYNACO A25

MECHANICAL DRAWING

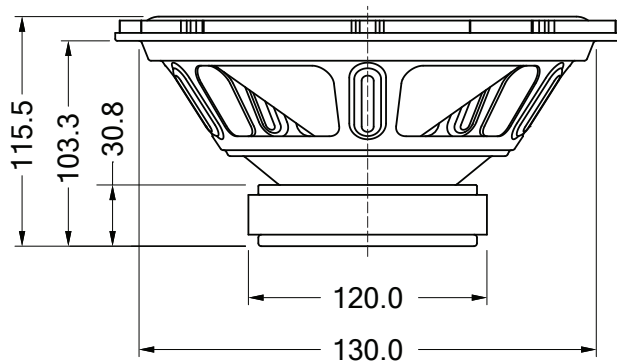

FEATURES

- Meticulously crafted replacement woofer for the Dynaco A-25 speaker
- Lighter cone design for improved transient response and accurate music reproduction
- Aging considerations addressed with a softer suspension
- Fully compatible with the Dynaco A25's Crossover Network
- Underdamped woofer design for precise performance with the original A25 cabinet
- Great replacement speaker

IMPEDANCE/PHASE

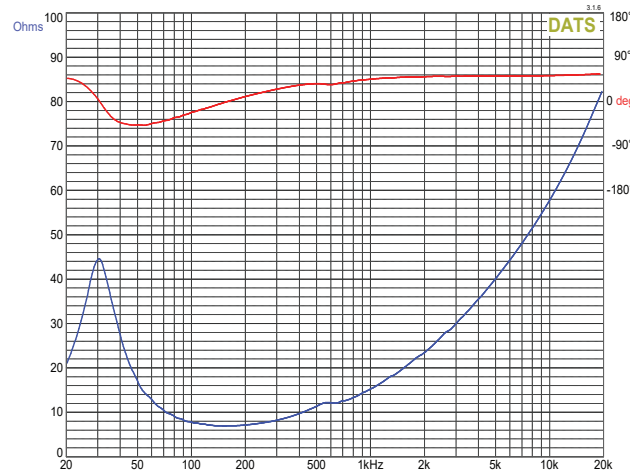

PARAMETERS

Impedance	6 ohms
Re	6.6 ohms
Le	1.7 mH@1k
Fs	30 Hz
Qms	2.50
Qes	0.43
Qts	0.37
Mms	49.6 g
Cms	0.55 mm/N
Sd	346 cm ²
Vd	155.7 cm ³
BL	12.0 Tm
Vas	91 liters
Xmax	4.5 mm
VC Diameter	38 mm
SPL	89.6 dB @ 2.83V/1m
RMS Power Handling (AES 426B)	70 watts
Usable Frequency Range (Hz)	30 - 4,500 Hz

FREQUENCY RESPONSE

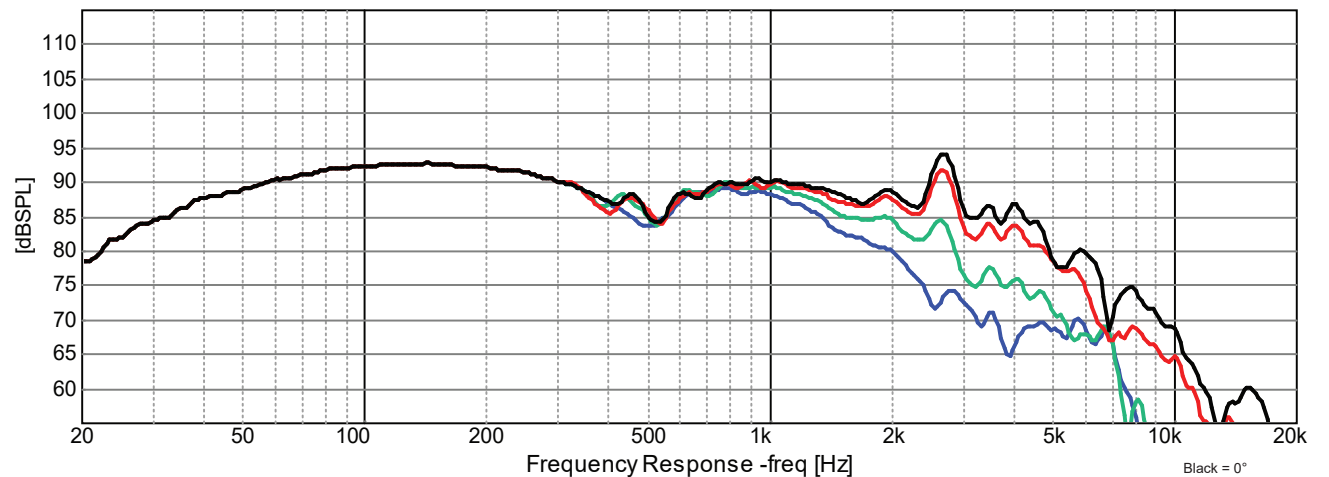

Note: 1/24th octave smoothing - nearfield response included in graph below 450 Hz.

Black = 0°
Red = 15°
Green = 30°
Blue = 45°