

ICEpower a/s, Vandtårnsvej 62A, 3rd floor B, DK-2860 Søborg
info@icepower.dk, www.icepower.dk

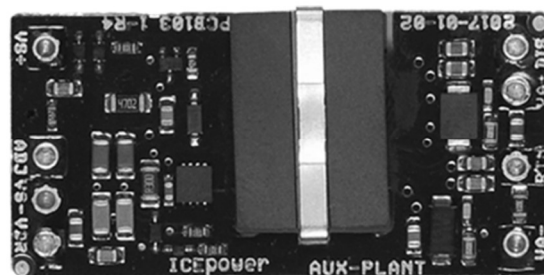

ICEpower AUX-plant

ICEbricks

ICEpower AUX-plant

AUX-plant is a compact and very versatile DC/DC converter

AUX-plant is a compact and very versatile DC/DC converter

1 Contents

1	CONTENTS	2
2	GENERAL DESCRIPTION	3
2.1	Key Specifications	3
3	DOCUMENT HISTORY	4
4	GETTING STARTED	5
5	BLOCK DIAGRAM	5
6	CONNECTION PINS	6
7	ABSOLUTE MAXIMUM RATING	6
8	ELECTRICAL SPECIFICATIONS	6
9	MECHANICAL SPECIFICATION	8
9.1	Dimensions	8
9.2	Mounting Holes (move to connector section)	8
10	OUTPUT VOLTAGE LOAD REGULATION	8
11	TYPICAL CHARACTERISTICS AND APPLICATION CONSIDERATIONS	10
11.1	Efficiency	10
11.2	Input and output decoupling	11
11.3	Output voltage adjust	12
11.4	Disable	12
11.5	Protection	13
12	THERMAL CONSIDERATIONS	13
13	APPLICATION INFORMATION	13
14	ESD WARNING	14
15	ORDERING, PACKAGING AND STORAGE	14
15.1	Ordering information	14
15.2	Shipping dimensions and weight	14
15.3	Storage conditions	14
16	CONTACT	15
17	LEGAL NOTES	15

AUX-plant is a compact and very versatile DC/DC converter

2 General Description

AUX-plant is a compact, very versatile DC/DC converter that can be used to supply many different class d amplifiers with supplies for OPAMPs and gate drivers. The VA+/VA- outputs are floating and can be referenced to either system ground or to the negative input voltage. VA+ and VDR can be paralleled to form a high current output which can be referenced to the negative input voltage or to system ground. The module is capable of generating up to 20W continuous power and up to 30W peak power. The output voltage can be adjusted from initial 15V down to 10V by an external resistor connected to the adjust pin. The module is equipped with over voltage protection and short circuit protection. By applying a logic voltage (or higher) on the DIS pin the module enters sleep mode.

NOTICE: The VDR voltage is fully regulated and the VA+/VA- are semi-regulated. This means that VA+/VA- voltages will vary with load. See the section regarding load regulation before using the AUX-plant. Loading VDR without any load on VA+/VA- can result in voltages on VA+/VA- up to 19V.

Features	Benefits
Very versatile input voltage range	Works with many applications with different available voltages
High efficient with very low idle consumption lead to no need of heat sink	Easy thermal management
< 600mW idle consumption and high efficient design	Very small size and no need for external heatsink
Simple mounting through wave soldering	Easy mechanical integration
Clever design having few component count	Robust design
Extremely compact considering its output power of 20W continuous 30W peak	Very powerful and versatile AUX-plant being very small in size

2.1 Key Specifications

- +/-15V analog supply and 15V gate drive supply
- 20W continuous output power (30W peak)
- Nominal Input voltage range from 30V to 100V (operates from 21V)
- Adjustable output voltage down to 10V
- 35 V output noise in the audible bandwidth (10Hz-22kHz)
- Efficiency > 80% @ Pmax
- < 600mW idle consumption
- 1mA standby consumption
- Very flexible design for use in many different applications
- Easily delivers all the needed aux supplies for 16 x Engine400 amplifiers

AUX-plant is a compact and very versatile DC/DC converter

3 Document History

Version	Date	Revised by	Changes
1.0	2016-03-22	LPP	First revision
1.1	2017-10-05	DIT	Datasheet redesign

AUX-plant is a compact and very versatile DC/DC converter

4 Getting Started

The AUX-plant is built on the same concept as the Engine-400 i. e. using the multilayer PCB as both heat sink but here also as inductor winding. It is very versatile in that the VA+/- outputs can be referenced to whatever supply rail you as a customer wish (usually GND in a single ended amplifier and or VS- in a single supply full bridge). VA+ can deliver more than 1A and if paralleled with VDR, up to 1,5A at +15V. The output voltages can also be trimmed with an external resistor in the range between 10-15V. The control loop on the AUX-plant has been built discretely with a matched differential pair to maintain a low noise behavior (approximately 30uVrms) even at low powers down to below 1W. There is also no integrator in the loop which means it starts nicely without overshoots. The output can handle a large span of capacitance so you are free to experiment.

Further details around how to design an application around AUX-plant can be found in the application notes.

5 Block Diagram

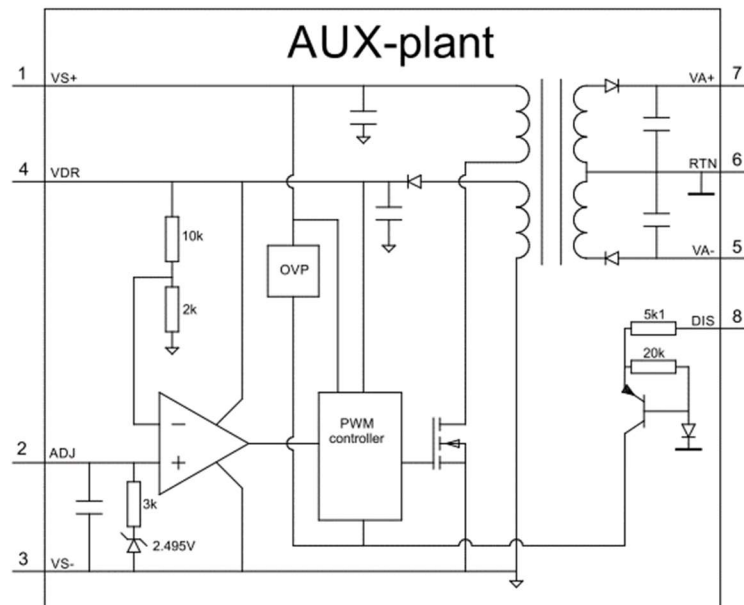

Figure 1: AUX-plant block diagram

AUX-plant is a compact and very versatile DC/DC converter

6 Connection pins

AUX-plant comes with custom, massive brass pins. Their job is to hold the module to the motherboard and to distribute heat and current to the motherboard.

Pin	Name	Description
1	VS+	Positive input voltage
2	ADJ	By connecting a resistor between this pin and VS-, the reference for the internal regulator is divided and the output voltages adjusted.
3	VS-	Negative rail input voltage
4	VDR	Regulated output voltage referenced to VS-
5	VA-	Semi regulated negative output voltage referenced to RTN (return).
6	RTN/GND	Return pin for VA+ and VA-. Can be connected to any polarity within the absolute maximum range.
7	VA+	Semi regulated positive output voltage referenced to RTN (return).
8	DIS	Disable pin referenced to RTN.

Table 1. Pin description

7 Absolute Maximum Rating

Characteristics	Min	Typ	Max	Unit	
T_{p1}	Ambient operating temperature (Pout=20W)		-20	45	°C
T_{p2}	Ambient operating temperature (Power dependent)		-20	80	°C
T_s	Storage temperature		TBD	TBD	°C
V_{in}	Voltage between VS+ and VS-			100	V
V_{off}	Offset voltage between VS- and RTN			150	V
V_{dis}	Voltage on disable (DIS) pin			20	V
R_{adj}	Minimum adjustment resistance (Radj)		3.9k		Ω

Table 2. Absolut maximum ratings

8 Electrical Specifications

For $V_{in} = 50V$, $T_{amb} = 25^{\circ}C$, unless otherwise specified. Measured with additional components: $C_{in} = 470\mu F$, $C_{VDR} = 330\mu F$, $C_{VA+} = 330\mu F$, $C_{VA-} = 330\mu F$. (Capacitor: 330uF/25V, EEUFC1E331)

Characteristics	Conditions	Min	Typ	Max	Unit	
V_{inFP}	Input voltage	Full Power		30	100	V
V_{in}	Input voltage	$I_{DRV}=I_{VA+}=I_{VA-}=100mA$		17	100	V
V_{UVL}	Under voltage lock-out		16		V	
V_{Start}	Start up voltage	$I_{DRV}=I_{VA+}=I_{VA-}=100mA$		21	V	
V_{OVP}	Over voltage protection		110		V	
P_{out}	Total continuous output power	$V_{in} = 30V - 100V$		20	W	
P_{outP}	Total peak output power	$V_{in} = 30V - 100V$		30	W	
t_{P_PWR}	Duration of peak power	$V_{in} = 30V - 100V$		5 ¹	S	
V_{DIS}	Disable trigger voltage	2.4			V	
P_{STB}	Stand-by power consumption	$V_{in}=56V$		56	mW	
η	Efficiency	30V		82	%	

AUX-plant is a compact and very versatile DC/DC converter

$I_{OUT_{VA+}}$	Maximum continues output current				1	A
$I_{OUT_{PVA+}}$	Maximum Peak output current	Limited by thermal constraints			1.5	A
$I_{OUT_{VA-}}$	Maximum continues output current				0.35	A
$I_{OUT_{PVA-}}$	Maximum Peak output current	Limited by thermal constraints			0.5	A
$I_{OUT_{DRV}}$	Maximum continues output current				0.35	A
$I_{OUT_{PDRV}}$	Maximum Peak output current	Limited by thermal constraints			0.5	A
C_{LOAD}	Maximum capacitive load per output	Test cap: 330 μ F - 10mF C*ESR: 10 μ Ω F - 20 μ Ω F			10	mF
I_{C_RMS}	AC capacitor current on outputs	V_{A+} (I=1A)			2	A
		V_{A-}, V_{DRV} (I=0,35A)			0,9	
t_{short}	Maximum time in short circuit	Input voltage range $Z_{Short} < 10m\Omega$		Inf.		s
C_{int}	Internal capacitance	Input		2		F
		Output VDR		20		
		Output VA+		30		
		Output VA-		30		
f_{SW}	Switching frequency			133		kHz
V_{DRV}	Initial output voltage setting	No load VDR	14.8	15	15.2	V
V_{DRV}	Initial output voltage setting	All Vin, 0-350mA	14.5		15.2	V
V_{tr}	Load transient voltage deviation	VA+	Load step 0.1-1-0.1A		1 ²	V
		VA- /VDR	Load step 50m-0.35-50mA		0.3 ² /0.1	
t_{tr}	Load transient recovery time				2	ms
t_s	Start up rise time	From V_{in} connection to 90% of V_{OUT} at P_{MAX}			120	ms
t_r	Ramp up time	From 10% to 90% of V_{OUT} at P_{MAX}		10		ms
t_{DIS}	Disable output voltage fall time	At P_{MAX} (10% V_{OUT})		4		ms
		At no load (10% V_{OUT})		2		s
	Enable voltage rise	At P_{MAX}	5		150	ms
V_{Oac}	Output voltage ripple	5W		0.2		Vpp
V_{O_no}	Output voltage noise	At P_{MAX} AES17 20kHz filter		35		V

Table 3. Electrical specifications.

¹Time depends on temperature

²For the VA+ and VA- output, the load regulation is the cause of the majority of the voltage variation.

AUX-plant is a compact and very versatile DC/DC converter

9 Mechanical Specification

9.1 Dimensions

Symbol	Parameter	Condition	Min	Typ	Max	Unit
L	Module length			50		mm
W	Module width			25		mm
H	Module height				16.2	mm
Mass	Weight	AUX-plant		18		g

Table 5: Mechanical dimensions

9.2 Mounting Holes (move to connector section)

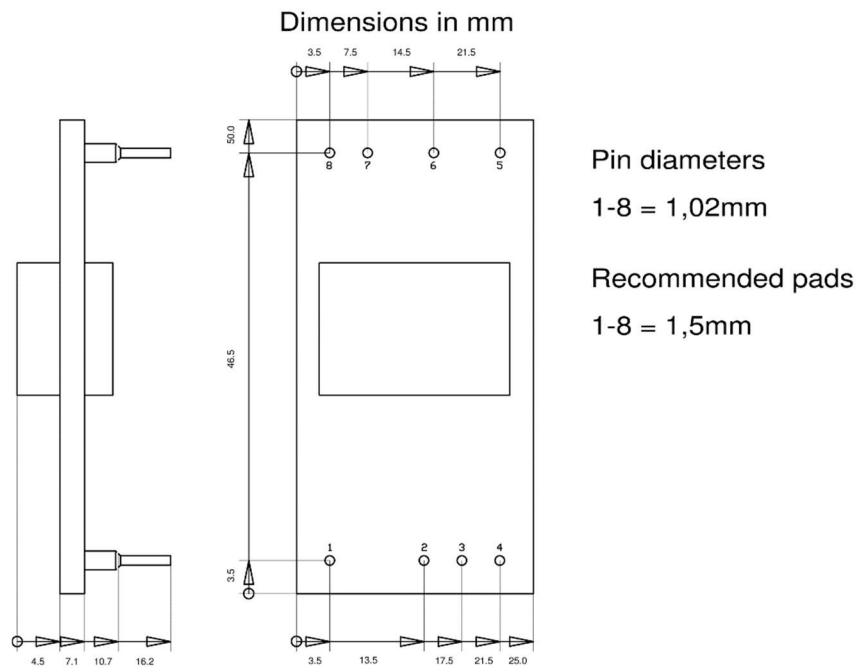

Figure 2: ICEbrick dimensions drawing and recommended pads for AUX-plant

10 Output voltage load regulation

The VDR voltage is directly regulated and the VA+ and VA- is semi regulated. This means that the voltages will vary with load. The best voltage tracking between the outputs is achieved when similar loads are connected to the outputs.

Because of the construction of the module, the maximum voltage to be expected will be on the VA+ output. This voltage is shown as a function of I_{DRV} and I_{VA+} for I_{VA-} equal to 0A, 100mA and 200mA.

AUX-plant is a compact and very versatile DC/DC converter

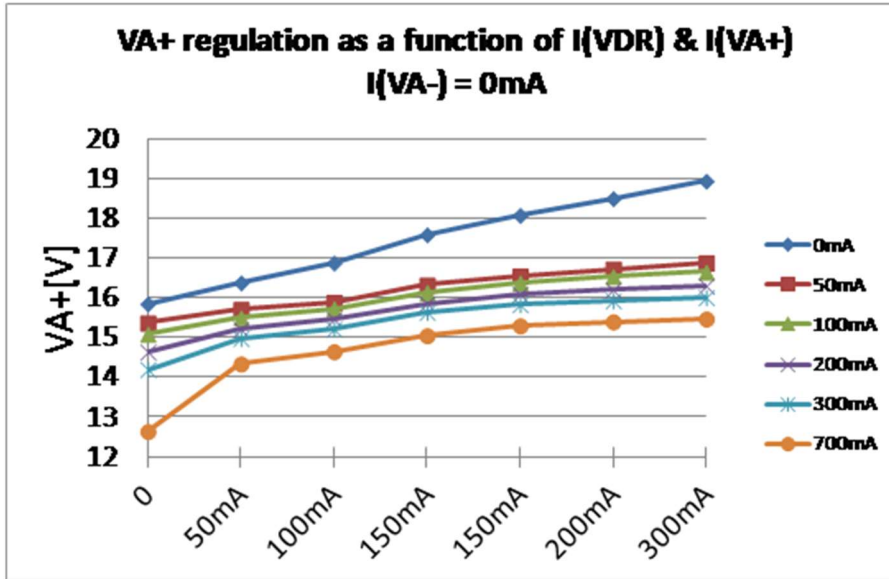

Figure 1. VA+ voltage as a function of load. I(VA-) = 0

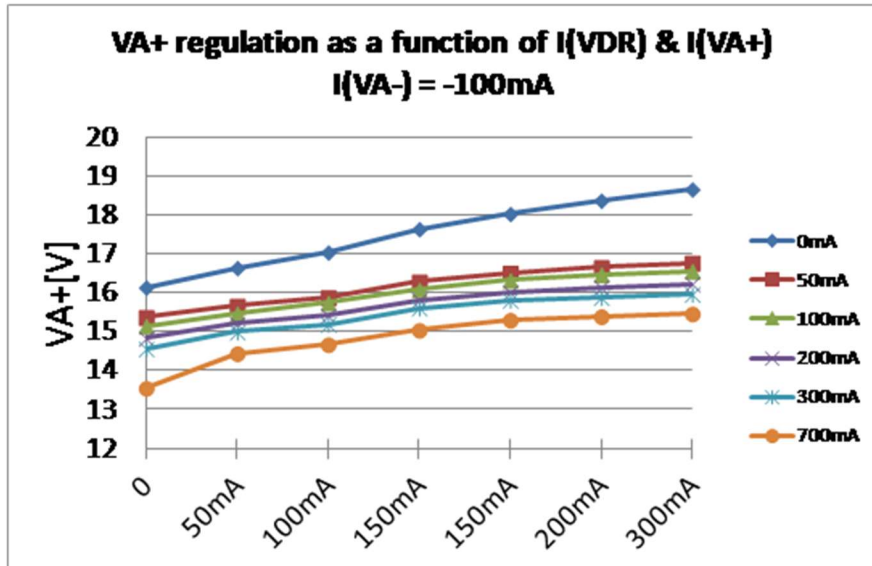

Figure 2. VA+ voltage as a function of load. I(VA-) = -100mA

AUX-plant is a compact and very versatile DC/DC converter

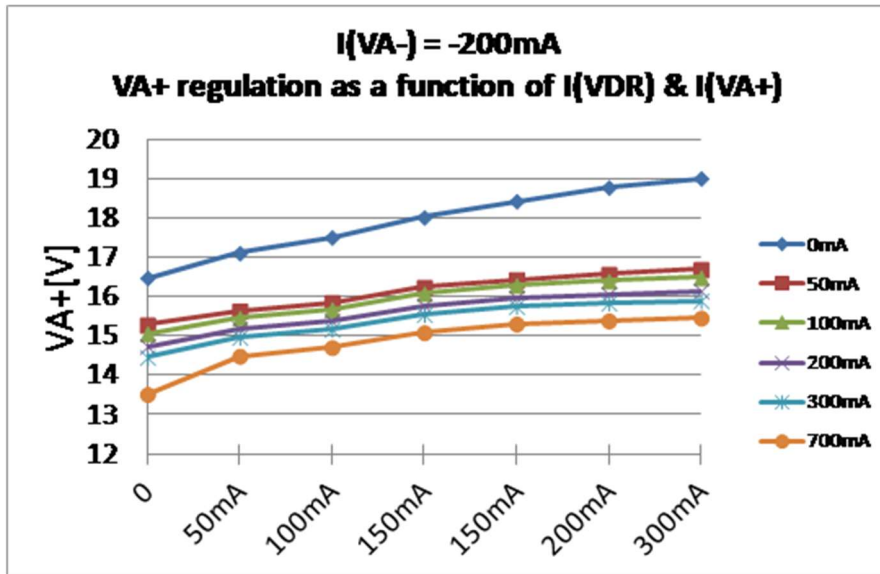

Figure 3. VA+ voltage as a function of load. I_{VA-}=-200mA

The Load regulation of the directly regulated output, VDR, is typically within 2% of the initial voltage.

11 Typical Characteristics and Application considerations

11.1 Efficiency

The efficiency of the module is shown in the below figure. The loading of the outputs follows a 2 to 1 ratio between I_{VA+} and I_{VA-/I_{DRV}} (I_{VA+}: I_{VA-}: I_{DRV} = 2:1:1). This means that if I_{VA+}=600mA, then I_{VA-}= I_{DRV} = 300mA.

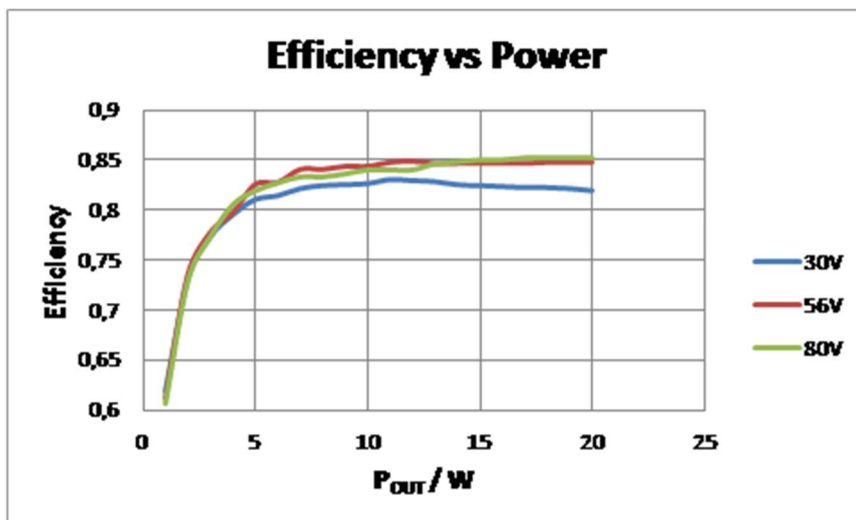

Figure 4. Efficiency as a function of output power

AUX-plant is a compact and very versatile DC/DC converter

11.2 Input and output decoupling

Both the input and the output voltages of the converter have to be decoupled properly by adding capacitors very close to in- and output pins. Size of capacitor should be scaled according to the power level. As a minimum one should choose capacitor with adequate voltage and current ratings. Below equations can be used to calculate current ratings for the input and output capacitors.

Note that the ripple current rating of the capacitors is the High Frequency (HF) rating given in the capacitor datasheets. Normally you will find a ripple current capability at different frequencies up to 100 kHz. Use the 100 kHz rating when specifying the capacitors for the module.

Input

The AC current from VS+ can be calculated using the below equation:

$$I_{C_RMS_IN} = \sqrt{\frac{\sqrt{8 \cdot P^3}}{7,3 \cdot V_{IN}} - \left(\frac{P}{V_{IN}}\right)^2}$$

P is the power and V_{IN} is the input voltage from VS+ to VS-.

Output

The AC current from VA+, VA- and VDRV can be calculated using the below equation:

$$I_{C_RMS_OUT} = \sqrt{\frac{\sqrt{8 \cdot P^3}}{2,4 \cdot V_{OUT}} - \left(\frac{P}{V_{OUT}}\right)^2}$$

P is the power and V_{OUT} is the voltage of the specific output.

Example:

For the VA+ output, the maximum continuous output current is 1A. The output voltage is 15V, so the output power is 15W. In this case, the AC RMS current and thereby the capacitor RMS current will be:

$$I_{C_RMS_OUT} = \sqrt{\frac{\sqrt{8 \cdot 15^3}}{2,4 \cdot 15} - \left(\frac{15}{15}\right)^2} = 1,86A_{RMS}$$

For the VA- output, the maximum continuous output current is 0,35A. In this case, the AC RMS current and thereby the capacitor RMS current will be:

$$I_{C_RMS_OUT} = \sqrt{\frac{\sqrt{8 \cdot 5,25^3}}{2,4 \cdot 15} - \left(\frac{5,25}{15}\right)^2} = 0,9A_{RMS}$$

AUX-plant is a compact and very versatile DC/DC converter

11.3 Output voltage adjust

The output voltage is adjustable in a range from 10 to 15 volt by placing a resistor between the ADJ pin and the VS- pin. If left open (no resistor added) the output voltage is the nominal 15V.

Within the nominal adjust range, the output follows the below equation and graph shown in figure 13.

$$V_{OUT} = \frac{15 \cdot R_{adj}}{R_{adj} + 3k\Omega}$$

,where R_{adj} is the resistor on the adjust pin tied to ground and V_{OUT} is the desired output voltage on VDR with a valid range from 10 to 15V.

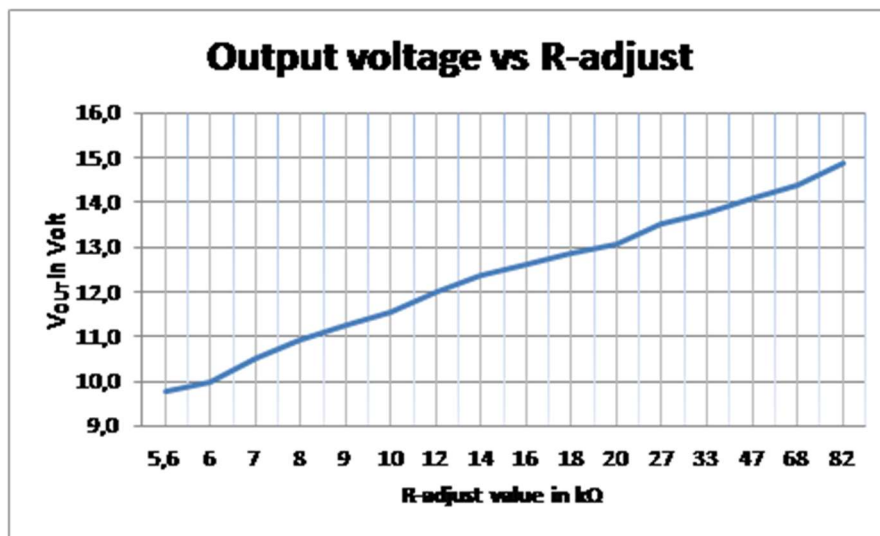

Figure 5. Output voltage as a function of R-adjust

It is not recommended to use resistor values below 3,9kΩ.

11.4 Disable

The AUX-plant can be disabled by applying a voltage on the DIS pin, which is referenced to RTN. This low trigger voltage ensures compatibility with low voltage digital signals, as can be applied from microcontrollers or DSPs. The minimum disable voltage is 2,4V and the maximum current into the disable pin is 2mA. This limits the voltage at the disable pin to approximately 10V. If the amplitude of the disable signal (V_{DIS}) is larger than 10V, a series resistor should be added. This series resistor can be calculated as:

$$R_{Series} = \frac{V_{DIS} - 10V}{2mA}$$

AUX-plant is a compact and very versatile DC/DC converter

11.5 Protection

OVP: In case the voltage between VS+ and VS- exceeds 100V the module is disabled.

UVLO: The module starts at 21V and shuts down at 16V

OC: The module is short circuit protected on all outputs. Exception in case the VDR output is loaded with less than 15mA and the short occurs on either VA+ or VA-.

OT: The module is also thermally protected in case the output power exceeds 20W. The thermal protection reduces the output voltage until the converter turns off. The thermal protection is only valid as long as maximum peak ratings of the outputs are not exceeded.

Exceeding maximum ratings may cause the module to fail.

12 Thermal considerations

Generally, the module is designed to drive 20W continuous in ambient temperatures up to 45°C given the individual current ratings of the outputs are not exceeded. Any use outside these specifications should be tested by the customer.

13 Application information

See specification for Motherboard-1 for further application notes, recommended PCB design and instructions of use.

AUX-plant is a compact and very versatile DC/DC converter

14 ESD warning

ICEpower products are manufactured according to the following ESD precautions:

- ANSI/ESD-S20.20-2007: Protection of Electrical and Electronic Parts, Assemblies and Equipment.

Further handling of the products should comply with the same standard.

The general warranty policy of ICEpower a/s does not cover ESD damaged products due to improper handling.

15 Ordering, Packaging and Storage

All ICEpower modules are packaged in ESD safe bobble bags and cardboard boxes.

15.1 Ordering information

Order Codes	Description	Part Number
ICEpower AUX-plant	AUX-plant is a compact and very versatile DC/DC converter	8004003

15.2 Shipping dimensions and weight

Package	Quantity	Dimensions (w × d × h) [mm]	Gross Weight [kg]
Carton	54 Modules	570 × 380 × 110	2.4
Pallet	40 Cartons	1200 × 800 × 1350	96

15.3 Storage conditions

Stacking

Pallets may not be stacked on top of each other.

AUX-plant is a compact and very versatile DC/DC converter

16 Contact

For additional information about the ICEpower® technology from ICEpower a/s, visit our web site or contact us.

ICEpower a/s
Vandtårnsvej 62A. 3rd floor B
DK-2860 Søborg
Denmark

www.icepower.dk
info@icepower.dk

17 Legal Notes

ICEpower a/s believes that the information in this datasheet is accurate and reliable. However, it is provided "as is" without any warranties of any kind. ICEpower a/s and its suppliers, to the fullest extent permitted by law, disclaim all warranties, including the warranty of merchantability, warranty of non-infringement of third-party rights, and the warranty of fitness for a particular purpose. ICEpower a/s and its suppliers make no warranties about the accuracy, reliability, completeness, or timeliness of the material, services, software, text, graphics and links. In no event, will ICEpower a/s be liable to any party for any damages whether direct, indirect, special, consequential or other for any use or inability to use of this datasheet, including, without limitation, any damages for lost profits, business interruption, loss of programs or other data on your information handling system or otherwise, even if we are expressly advised of the possibility of such damages.

Information in this datasheet may contain technical inaccuracies or typographical errors. The information in the datasheet may be changed at any time without prior notice or obligation.

ICEpower® is a trademark of ICEpower a/s.

ICEpower a/s products are not authorized for use as critical components in life support devices or life support systems without the express written approval of the president and general counsel of ICEpower a/s. As used herein:

- Life support devices or systems are devices or systems which, (a) are intended for surgical implant into the body, or (b) support or sustain life, and whose failure to perform when properly used in accordance with instructions for use provided in the labelling, can be reasonably expected to result in a significant injury to the user.
- A critical component is any component of a life support device or system whose failure to perform can be reasonably expected to cause the failure of the life support device or system, or to affect its safety or effectiveness.

ICEpower a/s ©2016