



2x4

2-IN 4-OUT BOXED
AUDIO PROCESSOR



KIT

2-IN 4-OUT AUDIO
PROCESSOR BARE BOARD

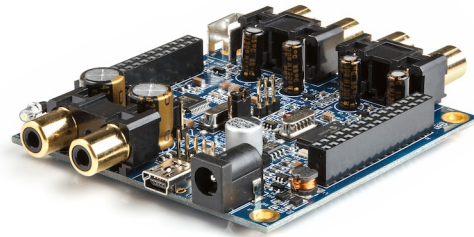

User Manual



Revision history

Revision	Description	Date
V1.5	miniDSP PCB revision - Rev1	31-05-2010
V1.6	New miniDSP PCB revision – Rev2	16-12-2010
V1.7	Jumper for RevA & B	26-03-2012
V2.0	Updated and revised for Rev3 PCB	15-06-2014
V2.1	Merged with kit manual	30-06-2014
V2.2	Added 2x4 Advanced plugin	15 May 2015
V2.3	Removed obsolete plugins, new product photographs	6 Oct 2015
V2.4	Revised installation procedure, Mixer plugin obsolete	31 Jan 2017
V2.5	Removing obsele plugins	14 March 2019



TABLE OF CONTENTS

- Important Information5
 - System Requirements.....5
 - Disclaimer/Warning.....5
 - Warranty Terms.....6
 - A Note on this Manual.....6
- 1 Product Overview7
 - 1.1 The miniDSP concept.....7
 - 1.2 Choosing the right miniDSP8
 - 1.3 Choosing a plugin9
 - 1.3.1 Two-way crossover plugins9
 - 1.3.2 Four-way crossover plugins 10
 - 1.3.3 Non-crossover plugins 11
 - 1.3.4 Subwoofer applications..... 11
- 2 The miniDSP Workflow 14
 - 2.1 Download and install the plugin..... 14
 - 2.1.1 Windows..... 14
 - 2.1.2 Mac 15
 - 2.2 Familiarize yourself with the plugin 16
 - 2.3 Go into online mode..... 17
 - 2.4 Perform initial configuration 18
 - 2.5 Get audio up and running..... 18
 - 2.5.1 Make audio connections 18
 - 2.5.2 Reconnect to the plugin 19
 - 2.5.3 Initial audio check..... 19
 - 2.6 Fine-tune your configuration..... 20
 - 2.7 Supply DC power 21
 - 2.8 Continue to operate offline 22
 - 2.8.1 Notes on powering the miniDSP in offline mode 22
 - 2.8.2 Notes on modifying the configuration while in offline mode 22
- 3 Plugin Architecture and Features 23
 - 3.1 System settings..... 23
 - 3.2 Input selection, level, and metering..... 25
 - 3.3 Output level, delay, and metering..... 26
 - 3.4 Graphic EQ..... 28
 - 3.5 Parametric EQ..... 29
 - 3.6 Crossover 31
 - 3.7 High pass and low pass filters..... 33
 - 3.8 Mono/stereo mode 33
 - 3.9 Keyboard shortcuts 34
 - 3.10 Custom biquad programming..... 35
 - 3.10.1 What’s a “biquad”? 35



- 3.10.2 Using custom biquad programming 35
- 3.10.3 The plugin calculator 37
- 3.10.4 Biquad calculation spreadsheet 37
- 3.10.5 Room EQ Wizard (REW)..... 37
- 3.10.6 Active Crossover Designer (ACD)..... 37
- 4 Optimizing gain structure 38
- 5 Kit documentation 39
 - 5.1 Board layout and features 39
 - 5.2 Expansion header and I2S connectivity 40
 - 5.3 USB connectivity 41
 - 5.4 Bypass/reset 41
 - 5.5 Volume control 42
 - 5.6 Master/Slave master clock selection..... 43
 - 5.6.1 Examples 43
- 6 Additional Information 44
 - 6.1 Specifications 44
 - 6.2 Troubleshooting 45
 - 6.3 Obtaining Support 46



IMPORTANT INFORMATION

Please read the following information before use. In case of any questions, please contact miniDSP via the support portal at minidsp.desk.com.

SYSTEM REQUIREMENTS

To configure the miniDSP 2x4, you will require a Windows PC or Apple Mac OS X computer with the following minimum specification:

Windows

- PC with 1GHz or higher processor clock speed. Intel® Pentium®/Celeron® family, or AMD K6®/AMD Athlon®/AMD Duron® family, or compatible processor recommended.
- 512 megabytes (MB) of RAM or higher
- Keyboard and mouse or compatible pointing device
- USB 2.0 port
- Microsoft® Windows® Vista® SP1/ XP pro SP2/Win7/Win8.1/Win10
- Microsoft® .NET framework v3.5 or later
- Adobe AIR environment (latest version)
- Adobe Flash player (latest version)

Mac OS X

- Intel-based Mac with 1 GHz or higher processor clock speed
- 512 megabytes (MB) of RAM or higher
- Keyboard and mouse or compatible pointing device
- Mac OS X 10.8 or higher
- USB 2.0 port
- Adobe AIR environment (latest version)
- Adobe Flash player (latest version)

DISCLAIMER/WARNING

miniDSP cannot be held responsible for any damage that may result from the improper use or incorrect configuration of this product. The miniDSP 2x4 is a powerful tool and can easily generate signals that will damage your audio system if not used properly. Please read this manual carefully to ensure that you fully understand how to operate and use this product.

To avoid mishap, be sure to configure the miniDSP 2x4 **before** connecting anything to its outputs, as described in the section [The miniDSP workflow](#). This will ensure that the software is correctly configured and will greatly reduce any chance of causing damage to your system. Once again, miniDSP cannot be responsible for any damage the miniDSP 2x4 may cause to your system.

Finally, note that the miniDSP 2x4 is a very flexible device, and many of the questions we receive at the tech support department are already answered in this user manual and in the online [application notes](#) on the miniDSP.com website. So please take the time to carefully read this user manual and the online technical support. And if an issue arises with your unit, please read through the [Troubleshooting](#) section first. Thank you for your understanding!

WARRANTY TERMS

miniDSP Ltd warrants this product to be free from defects in materials and workmanship for a period of one year from the invoice date. Our warranty does not cover failure of the product due to incorrect connection or installation, improper or undocumented use, unauthorized servicing, modification or alteration of the unit in any way, or any usage outside of that recommended in this manual. If in doubt, contact miniDSP prior to use.

A NOTE ON THIS MANUAL

This User Manual is designed for reading in both print and on the computer. If printing the manual, please print double-sided. The embedded page size is 8 1/2" x 11". Printing on A4 paper will result in a slightly reduced size. For reading on the computer, we have included hyperlinked cross-references throughout the manual. In addition, a table of contents is embedded in the PDF file. Displaying this table of contents will make navigation much easier:

- In Adobe Reader on Windows, click on the “bookmarks” icon at the left. The table of contents will appear on the left and can be unfolded at each level by clicking on the “+” icons.
- In Preview on the Mac, click on the **View** menu and select **Table of Contents**. The table of contents will appear on the left and can be unfolded at each level by clicking on the triangle icons.

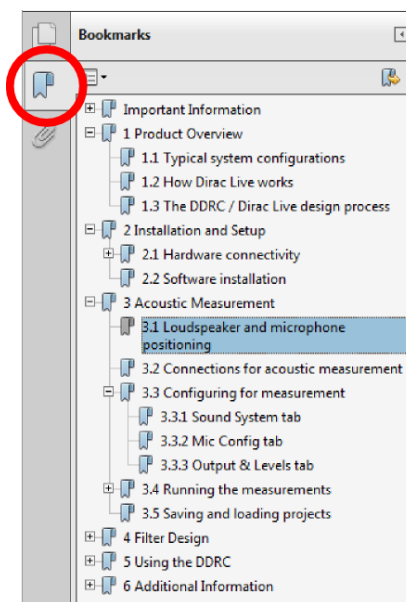

Adobe Reader on Windows

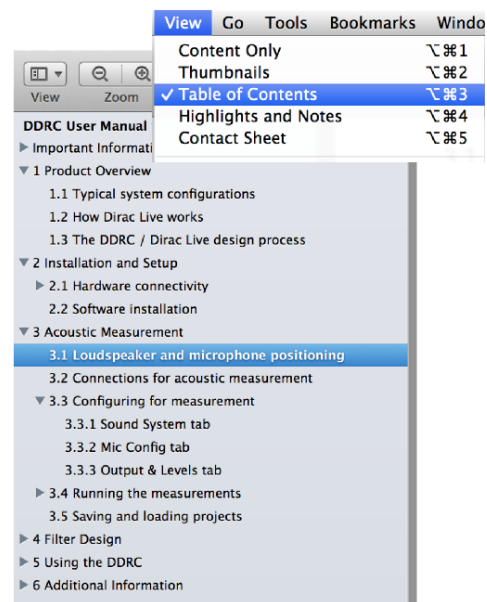

Preview on Mac

1 PRODUCT OVERVIEW

Thank you for choosing the miniDSP kit board or the miniDSP 2x4 audio processor. Combined with an extensive range of plugins, the miniDSP kit and miniDSP 2x4 offer a compact, inexpensive, yet powerful and flexible platform for many audio applications:

- Active crossovers
- System equalization with graphic or parametric EQ
- Subwoofer integration
- Audio mixing and routing
- Center and rear channel synthesis

1.1 THE MINIDSP CONCEPT

The miniDSP concept is “one hardware unit + one software plugin = audio processing solution.” This concept leverages the inherent flexibility of DSP (digital signal processing) to deliver a range of flexible but cost-effective solutions.

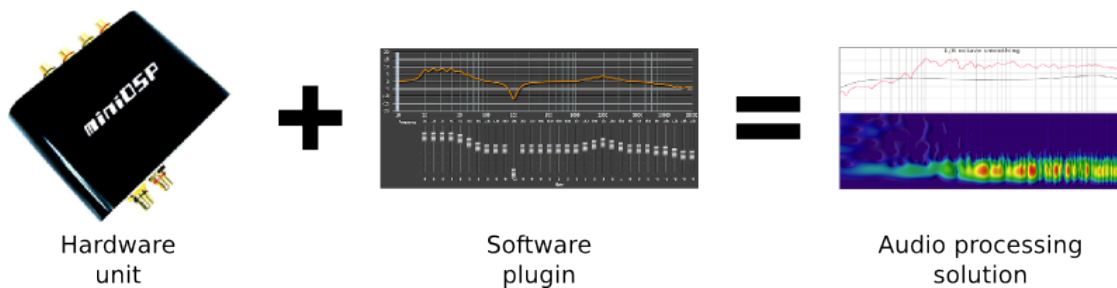

Hardware unit

In this case, the hardware unit is the miniDSP 2x4 or miniDSP kit. It has two analog inputs and four analog outputs. The internal processor converts the analog input signal to digital form, processes it according to the instructions from the plugin, and then converts it to analog again for the outputs. See [Choosing the right miniDSP](#) for more information on miniDSP hardware.

Software plugin

The software plugin is installed on your PC or Mac, and determines the processing that the DSP will perform. It provides a friendly user interface, and downloads instructions into the miniDSP hardware unit that tell it how to process the incoming audio signal. See [Choosing a plugin](#) for more information on plugins.

1.2 CHOOSING THE RIGHT MINIDSP

The miniDSP 2x4 and miniDSP kit provides two analog inputs and four analog outputs. They are a simple, cost-effective DSP solution for many audio processing needs. They are also an excellent starting point for learning about DSP for audio applications.

The **miniDSP 2x4** is a self-contained “miniDSP in a box”:



The **miniDSP kit** consists of just the circuit board without the external chassis. The board can be integrated into any build that requires the addition of flexible yet cost-effective audio processing.



miniDSP make a large and growing number of hardware platforms for particular needs. If the 2x4 is not the most suitable hardware, then other options are available.

miniDSP Balanced 2x4

Used for applications that require balanced audio connections, such as in pro-sound and in some car applications. Balanced connections provide additional immunity to noise over long cable runs and in electrically noisy environments.

Other platforms

miniDSP makes many other hardware units with up to ten output channels, with sophisticated digital room correction capabilities, and with inbuilt amplification (plate amps). Many are available in either kit or “boxed” form. See the [full range of miniDSP products](#).

1.3 CHOOSING A PLUGIN

The plugin that you choose depends on the specifics of your application. Currently, there are eight plugins available for the miniDSP 2x4 and miniDSP kit.

1.3.1 Two-way crossover plugins

A two-way crossover splits the audio frequency band into two. Typically, this is used to feed high frequencies to tweeters and low frequencies to woofers. A single miniDSP 2x4 or miniDSP kit is used for stereo, as shown in this diagram (protection capacitors on the tweeters are optional but generally recommended):

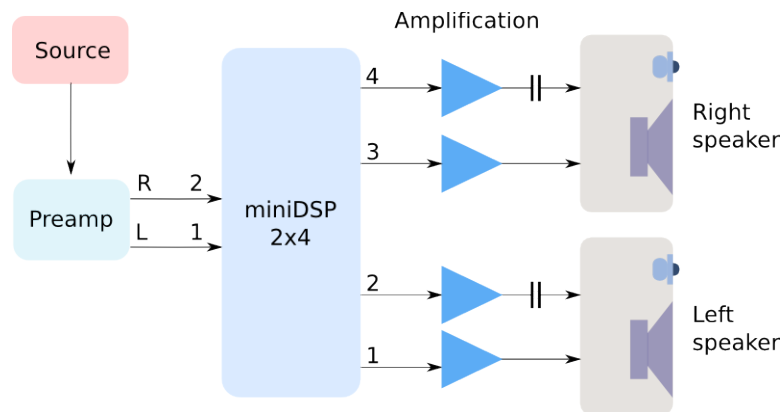

[2x4 Advanced](#)

The **2x4 Advanced** crossover plugin provides parametric EQ on both inputs and on all four outputs, fully independent crossovers/filters with a wide range of filter slopes (up to 48 dB/octave) on all four outputs, and a matrix mixer. Two-way active loudspeakers are among the wide range of applications supported by this plugin. For more information, see the [datasheet](#).

[2way Advanced](#)

The **2way Advanced** crossover plugin provides parametric EQ on both inputs and on all four outputs, as well as fully independent crossovers with a wide range of filter slopes up to 48 dB/octave. It is typically used for building fully active two-way loudspeakers. For more information, see the [datasheet](#). Note: in most applications, this plugin is superseded by the **2x4 Advanced** plugin (see above).

[2way Advanced 21](#)

The **2way Advanced 21** plugin is similar to the **2way Advanced** plugin, but it also allows two of the output channels to be summed together to provide a mono subwoofer feed. It is therefore used to derive a mono subwoofer signal from a stereo signal, or to create “sub sat” systems. For more information, see the [datasheet](#). Note: in most applications, this plugin is superseded by the **2x4 Advanced** plugin (see above).

1.3.2 Four-way crossover plugins

A four-way crossover splits the frequency spectrum of a single input channel into up to four distinct bands. Frequency bands can overlap if needed, as all crossover filters are independently specified. Two miniDSP 2x4 units or miniDSP kits are needed for stereo, as shown in this diagram (a protection capacitor on each tweeter is optional but generally recommended):

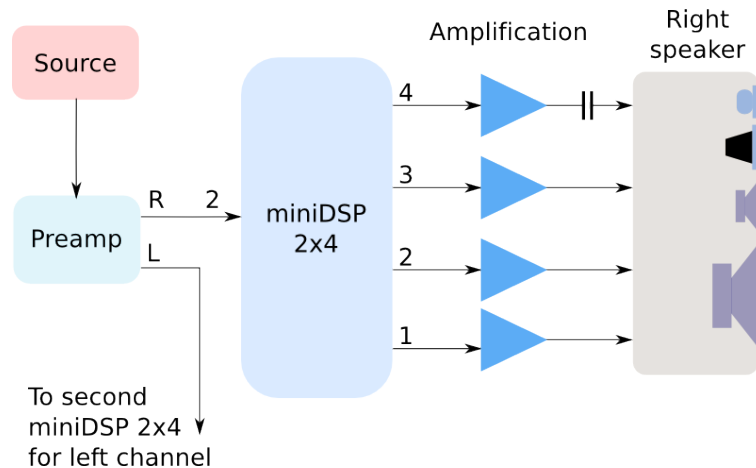

[2x4 Advanced](#) The new **2x4** crossover plugin provides parametric EQ on both inputs and on all four outputs, fully independent crossovers/filters with a wide range of filter slopes (up to 48 dB/octave) on all four outputs, and a matrix mixer. Three-way and four-way active loudspeakers are among the wide range of applications supported by this plugin. For more information, see the [datasheet](#).

[4way Advanced](#)

The **4way Advanced** plugin provides parametric EQ on one input channel and on all four output channels, as well as fully-independent crossovers with a wide range of filter slopes up to 48 dB/octave. It is typically used to build a fully active three-way or four-way active loudspeaker (two miniDSP hardware units required for stereo). For more information, see the [datasheet](#). Note: in most applications, this plugin is superseded by the **2x4 Advanced** plugin (see above).

1.3.3 Non-crossover plugins

Two plugins provide specialized audio processing functions.

Rear/Center Channel

The **Rear/Center Channel** plugin provides a summed (L+R) or difference (L-R or R-L) signal for use in deriving center or rear channels from a stereo signal. It also provides a 31-band graphic EQ, high pass and low pass filters, and long delay (total 31 ms). For more information, see the [datasheet](#).

1.3.4 Subwoofer applications

For subwoofer applications, we usually recommend the use of the **2x4 Advanced** plugin, because of its flexibility and ability to handle many different subwoofer configurations. This flexibility is provided by the use of the matrix mixer, which maps and mixes input channels to output channels. Here are four common subwoofer scenarios and the recommended routing for each.

Mono subwoofer from stereo signal, and high passed speakers

In this configuration, the miniDSP 2x4 or miniDSP kit is used to generate a single mono subwoofer feed from a stereo signal, as well as to high-pass the main speakers. The connection diagram is shown as follows:

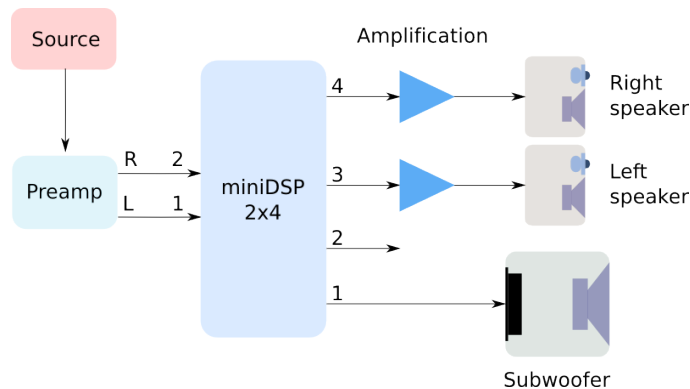

To accomplish this configuration, use the matrix mixer to mix input channels 1 and 2 to output 1, and to send input 1 to output 3, and input 2 to output 4:

	OUT #1	OUT #2	OUT #3	OUT #4
IN #1	<input checked="" type="checkbox"/> On	<input type="checkbox"/> Off	<input checked="" type="checkbox"/> On	<input type="checkbox"/> Off
IN #2	<input checked="" type="checkbox"/> On	<input type="checkbox"/> Off	<input type="checkbox"/> Off	<input checked="" type="checkbox"/> On

Stereo subwoofer from stereo signal

To derive a separate left and right subwoofer signal from the stereo left and right signals, input channel 1 is sent to outputs 1 and 2, and input channel 2 is sent to outputs 3 and 4 (this is essentially the same as a two-way crossover):

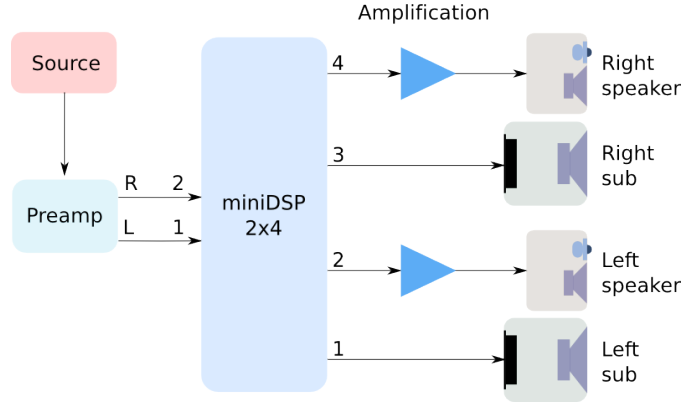

To accomplish this configuration, use the matrix mixer to send input channel 1 to outputs 1 and 2, and input channel 2 to outputs 3 and 4:

	OUT #1	OUT #2	OUT #3	OUT #4
IN #1	<input checked="" type="checkbox"/>	<input checked="" type="checkbox"/>	<input type="checkbox"/>	<input type="checkbox"/>
IN #2	<input type="checkbox"/>	<input type="checkbox"/>	<input checked="" type="checkbox"/>	<input checked="" type="checkbox"/>

One to four subwoofers from stereo signal

If the miniDSP is used only for subwoofer control/EQ, up to four separate subwoofer signals, each with different delay and EQ, can be generated from a stereo signal:

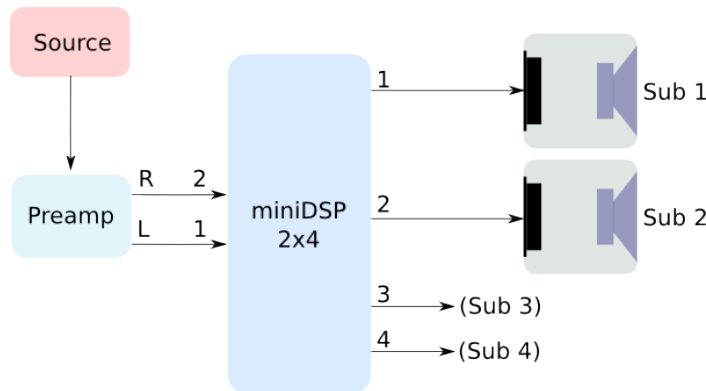

To accomplish this configuration, use the matrix mixer to mix both input channels to all four output channels:

	OUT #1	OUT #2	OUT #3	OUT #4
IN #1	<input checked="" type="checkbox"/>	<input checked="" type="checkbox"/>	<input checked="" type="checkbox"/>	<input checked="" type="checkbox"/>
IN #2	<input checked="" type="checkbox"/>	<input checked="" type="checkbox"/>	<input checked="" type="checkbox"/>	<input checked="" type="checkbox"/>



One to four subwoofers from mono signal (e.g. AVR)

If you have an A/V processor or A/V receiver, it has already combined various signals together to generate a single subwoofer signal. The miniDSP 2x4 can generate up to four subwoofer signals with different EQ and delay from the AVR subwoofer output:

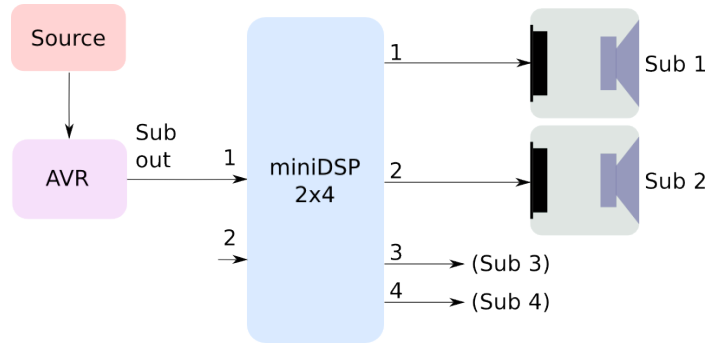

To accomplish this configuration, the routing matrix sends input channel 1 to all four output channels:

	OUT #1	OUT #2	OUT #3	OUT #4
IN #1	<input checked="" type="checkbox"/> On	<input checked="" type="checkbox"/> On	<input checked="" type="checkbox"/> On	<input checked="" type="checkbox"/> On
IN #2	<input type="checkbox"/> Off	<input type="checkbox"/> Off	<input type="checkbox"/> Off	<input type="checkbox"/> Off

Two to four subwoofers from dual mono signal (e.g. AVR)

Some A/V processors and A/V receivers provide two subwoofer outputs. You can send each input to any of the outputs. For example, this routing screen illustrates the case where input 1 is sent to output 1, and input 2 is sent to outputs 2 through 4:

	OUT #1	OUT #2	OUT #3	OUT #4
IN #1	<input checked="" type="checkbox"/> On	<input type="checkbox"/> Off	<input type="checkbox"/> Off	<input type="checkbox"/> Off
IN #2	<input type="checkbox"/> Off	<input checked="" type="checkbox"/> On	<input checked="" type="checkbox"/> On	<input checked="" type="checkbox"/> On

More advanced subwoofer applications

There may be cases where you need more features than provided by the miniDSP 2x4 and miniDSP Kit – for example, higher signal levels, longer delays, or more output channels. In that case, please see the more powerful miniDSP units [10x10 Hd](#), [nanoDIGI 2x8 b](#), [nanoAVR HD](#), and [nanoAVR HDA](#).

2 THE MINIDSP WORKFLOW

While each plugin is different, there is a common procedure or workflow that we recommend for all of them.

1. [Download and install the plugin](#)
2. [Familiarize yourself with the plugin](#)
3. [Go into online mode](#)
4. [Perform initial configuration](#)
5. [Get audio up and running](#)
6. [Fine-tune your configuration](#)
7. [Supply DC power](#)
8. [Continue to operate offline](#)

2.1 DOWNLOAD AND INSTALL THE PLUGIN

If you purchased your product directly from miniDSP, your software will be available from the [User Downloads](#) section of the miniDSP website when your order ships. You will need to be logged into the website with the account you created when purchasing to access the download.

If you purchased your product from a miniDSP dealer, you will receive a coupon together with the product. Redeem this coupon and select the plugin you ordered at the link below:

- <https://www.minidsp.com/support/redeem-coupon>

The User Downloads link is visible from the dropdown menu at the top right of the website page:

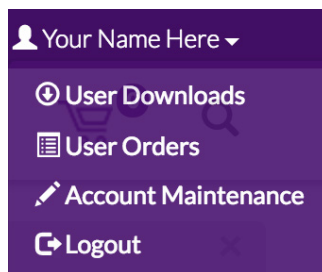

Navigate to the **miniDSP Plugins** section. Locate the plugin that you wish to download (only purchased plugins will be visible), and then click on the **Download** button.

Once the file is downloaded, unzip it (on Windows, right-click and select “Extract All...”; on Mac, double-click).

Note: the Adobe Air framework may need a network connection the first time the plugin is used. If the plugin does not start properly, see [Troubleshooting](#).

2.1.1 Windows

The miniDSP software requires that a number of other frameworks be installed for it to work. For Windows 7 and later, these packages will be installed automatically. For earlier versions of Windows, please download and

install the following frameworks before attempting to install any miniDSP software. You can also manually install these if you receive an error message that required software is missing.

- [Microsoft .NET framework](#) (version 3.5 or later)
- Latest version of [Adobe Flash](#)
- Latest version of [Adobe Air](#)

To install the plugin:

1. Navigate to the **Windows** folder of the software download.
2. Double-click on the **MiniDSP_Plugin.exe** installer program to run it. (The name will depend on the specific plugin that you downloaded.) We recommend that you accept the default installation settings.
3. The plugin will start automatically if you accepted the default installation settings. To make it quicker to run in future, right-click on its icon in the taskbar and select “Pin to taskbar.”

2.1.2 Mac

To install the plugin:

1. Navigate to the **Mac** folder of the software download.
2. The installer program is named **MiniDSP_Plugin.pkg**. (The name will depend on the specific plugin that you downloaded.) To run it, double-click on it, or right-click and open as described below. We recommend that you accept the default installation settings.

To run the plugin, locate it in the Applications -> miniDSP folder and double-click on it. To make it easier to run in future, right-click on its dock icon and select Options -> Keep in Dock.

Note: If double-clicking on an installer brings up a message that the installer cannot run, use this alternate method:

1. Right-click on the installer (or click while holding the Control key). (The name will depend on the specific plugin that you downloaded.)
2. On the menu that pops up, move the mouse over the “Open With” item and then click on “Installer (default).”

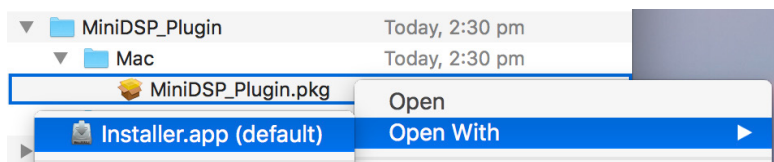

3. The following window will appear. Click on “Open.”



2.2 FAMILIARIZE YOURSELF WITH THE PLUGIN

Before connecting your computer to the miniDSP 2x4 or kit board, it's worth familiarizing yourself with the user interface presented by the plugin. When it starts, you will see the plugin screen as shown below. (This particular example is the **2way Advanced** plugin, but they all share a common layout.)

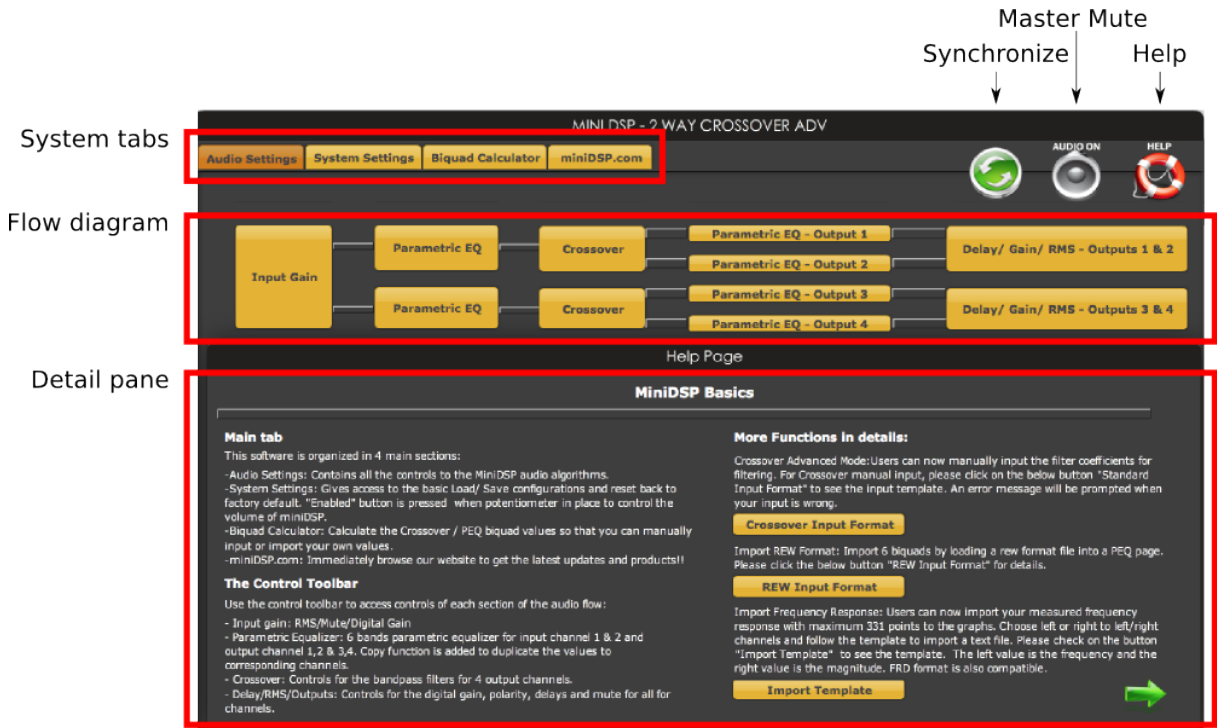

System tabs

These tabs access various screens to provide access to different types of functionality.

Control buttons (Synchronize, Master Mute, Help)

The **Synchronize** button connects the user interface to the miniDSP hardware unit, downloading configuration data and putting it into *online mode*. The **Master Mute** button enables or disables all audio processing. Finally, the **Help** button brings up the help screen (shown above).

Flow diagram

The flow diagram (or “block diagram”) is a schematic representation of the audio processing that takes place in the miniDSP hardware unit. Audio “flows” through the diagram from the inputs on the left to the outputs on the right. Clicking on each block will show its control interface in the detail pane underneath it.

Detail pane

The detail pane shows the control interface of the processing blocks in the flow diagram. For the specifics of each type of processing block, see [Plugin architecture and features](#).

Now is a good time to explore the plugin and become familiar with all of the controls in each of the signal processing blocks. Click on each of the blocks in the block diagram to see what the controls are.

At this time, the plugin is still in *offline* mode, so any changes you make will not be downloaded into the miniDSP hardware. Since we will reset all of the processing parameters in the next section, you can feel free to experiment with the user interface at this point.

2.3 GO INTO ONLINE MODE

A USB connection to your computer is needed to go into online mode. Simply connect the supplied USB cable from a free USB port on your computer to the miniDSP 2x4 or kit board. (In the case of the kit, see also [USB connectivity](#).) The USB connection will power the miniDSP hardware as well as provide data communication.

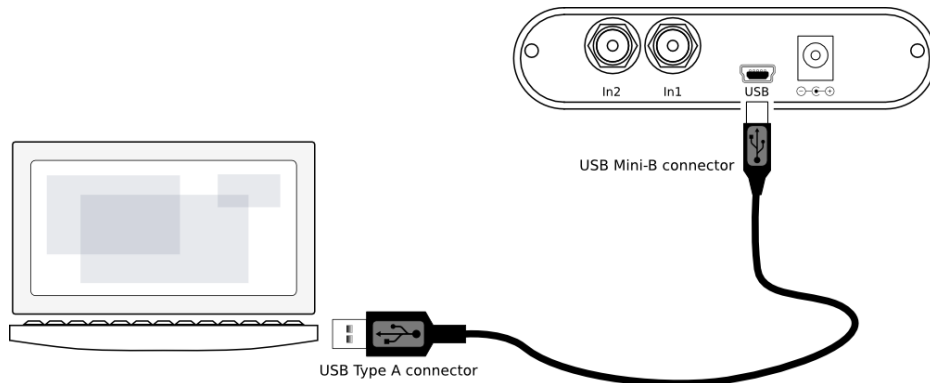

Don't connect other equipment to the miniDSP 2x4 or kit board at this stage. That will be done after correctly initializing the configuration.

Click on the **Synchronize** button, and the following dialog will appear:

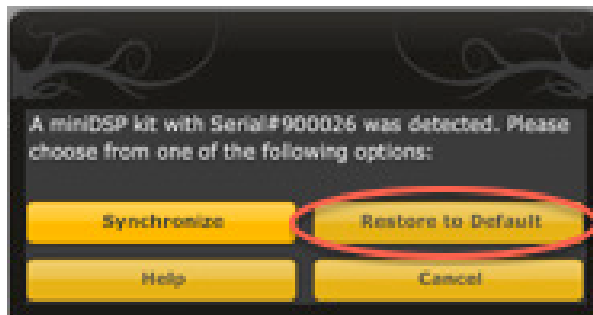

Click on the **Restore to Default** button. This is essential the *first time you connect to the miniDSP*, as it ensures that the miniDSP hardware unit contains an internal set of data that it understands. (Subsequently, you will generally use the **Synchronize** button.)

Provided all goes well, you will see a confirmation dialog. The plugin is now in *online mode*. Any change that you make in the plugin user interface will be immediately downloaded to the miniDSP hardware unit, so the change will take effect in real time.

2.4 PERFORM INITIAL CONFIGURATION

As long as you pressed **Restore to Default** above, your plugin and the onboard software in the miniDSP hardware have been set to their default state. Depending on your plugin and application, you may now need to change these settings to fit your specific application.

For example:

- Set crossover frequencies and slopes
- Set up any essential equalization
- Mute unused input and output channels

At this point, save your initial configuration to a file. A *configuration* is the set of all audio processing parameters. You should save your configuration to a file on a regular basis, to ensure that you do not lose your work if you inadvertently restore the miniDSP to default settings. For more information on configurations, see [System settings](#).

2.5 GET AUDIO UP AND RUNNING

With the initial configuration done and now that you are familiar with the various controls, it's time to connect the miniDSP into your system. Before doing so, *unplug the USB cable* from the miniDSP 2x4 or kit board.

2.5.1 Make audio connections

Analog audio input and output connections are made directly to the RCA input and output jacks. When making these connections, make sure that the equipment being connected is powered *off*.

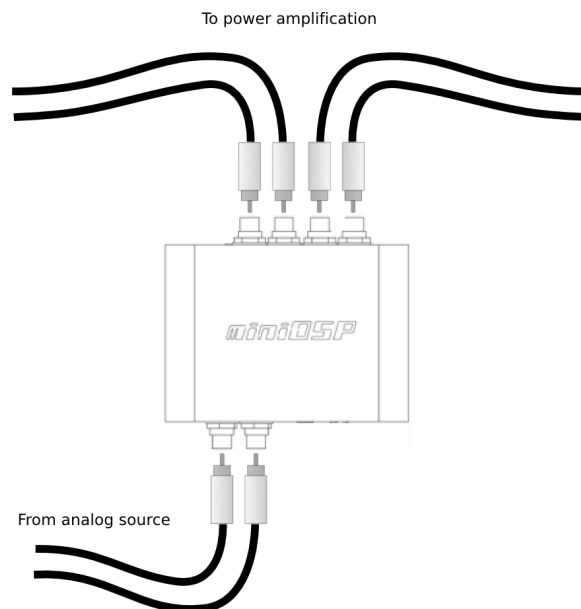

The specific use of input and output connections depends on your application and the plugin chosen. See [Choosing a plugin](#) for more information.



When making analog audio connections, just push the RCA connectors on and pull them off. Try to avoid twisting the plugs to get them on and off.

2.5.2 Reconnect to the plugin

With the connected equipment still turned *off*, reconnect the USB cable to the computer. You can optionally connect an auxiliary power supply at this time – see [Supply DC power](#). Click on the **Synchronize** button again. This time, be sure to select the **Synchronize** option from the dialog box:

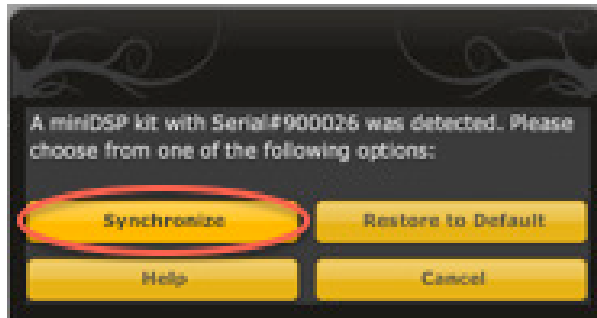

The miniDSP is now in online mode again.

2.5.3 Initial audio check

Power on your connected equipment: first on the input side (e.g. preamp), then on the output side (e.g. power amps).

Turn the volume on your source and/or amplification down low, and start playing music or a pink noise test signal. Gradually increase the volume until you hear audio quietly coming from the speakers. Verify that the plugin is performing the intended function. For example, if you are implementing a two-way crossover, confirm that the tweeter is playing high frequencies, and that the woofer is playing low frequencies. (If you have a measurement microphone and software that allows real time spectrum analysis, then by all means use it.)

2.6 FINE-TUNE YOUR CONFIGURATION

With your initial setup running, you can now proceed to fine-tune and optimize your system.

Although there are some applications where you can perform tuning by ear, applications like active crossovers and subwoofer integration are best optimized with the aid of acoustic measurements. The miniDSP [UMIK-1](#) is an ideal accessory for this purpose, and works with any measurement program including the free [Room EQ Wizard](#).

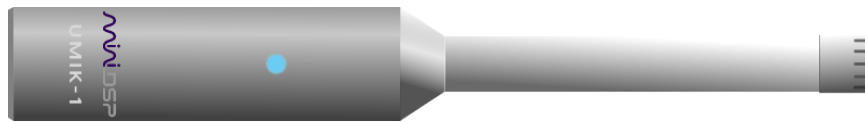

For active crossovers

Measure each driver individually, at (typically) a distance of 0.5 or 1 meter (1.5 or 3 feet). Use these measurements to adjust the parametric equalizer for each driver, and to fine-tune the crossover (frequency and slope) settings.

For subwoofer integration

Measure the subwoofer with the microphone placed at the listening position. Typically, moving the subwoofer to find the best response without EQ will yield best performance after EQ. The REW auto-EQ function can be used to quickly generate an optimum equalization setting.

For room correction

Measure the response of the system with the microphone placed at the listening position. Apply equalization using either the graphic equalizer or parametric equalizer. Adjustments can be confirmed by measurement as well as listening.

For more detailed information on these topics, see our extensive collection of application notes on [acoustic measurement](#) and [digital crossovers](#).

Be sure to save your configuration on a regular basis while working on fine-tuning it. Configurations can be saved to different files, in order to archive different versions, or to enable auditioning of alternative configurations. See [System settings](#) for more information on configurations.

2.7 SUPPLY DC POWER

Once you have all of the parameters to your liking, *first turn off any connected equipment*, and then disconnect the USB cable from the miniDSP 2x4 or kit board.

To be able to continue to operate the miniDSP in offline mode (without the computer connected), you will need to provide an alternate power source. There are two options:

- Connect the USB cable to a 5VDC USB charger. The 2x4 or kit board requires 150 mA of current, so almost any USB charger should be adequate.

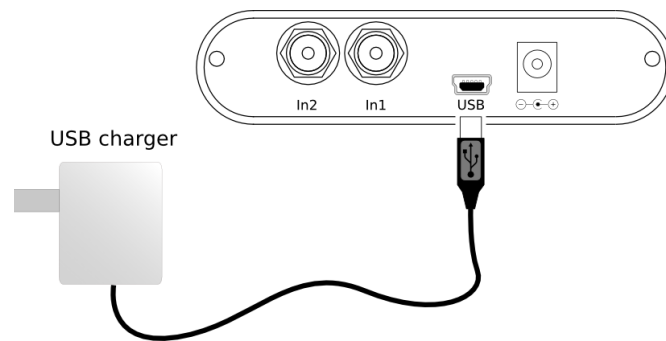

- Connect an auxiliary DC power supply to the 2.1mm DC power connector. The power supply voltage can be in the range of 4.5 to 24 VDC, enabling use of a wide range of power sources.

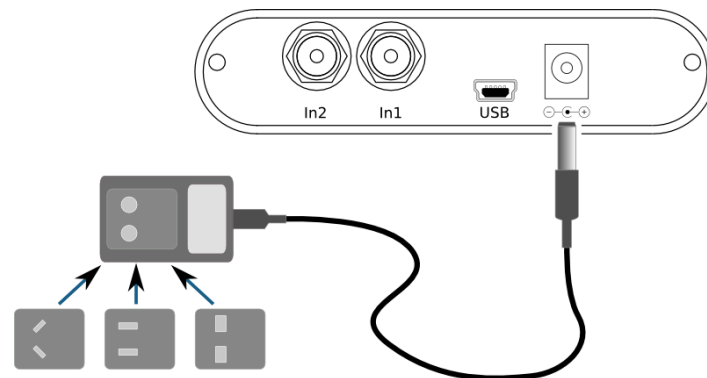

The DC power connector must have the positive voltage on the center pin. Be sure to check this before connecting the power supply, as otherwise your unit may be damaged.

Note: Prior to Rev3 of the miniDSP circuit board (released in June 2014), auxiliary power for the miniDSP 2x4 and miniDSP kit is provided via a Phoenix connector with screw terminals instead of a 2.1mm DC connector. If you have an older version of the board, please refer to the older manuals [miniDSP 2x4 User Manual v1.7](#) or [miniDSP kit User Manual v1.6](#) for the correct power supply connection.

2.8 CONTINUE TO OPERATE OFFLINE

With your miniDSP hardware and software configured and a DC power source connected, you can continue to operate the miniDSP in offline mode – that is, without the computer connected. To do so, simply turn the connected equipment on again – source and preamp first, then power amps. The miniDSP “remembers” the configuration last set, and will continue to operate without the computer.

2.8.1 Notes on powering the miniDSP in offline mode

3. If using an auxiliary DC power supply, the USB cable to the computer can be reconnected at any time, with no ill effects.
4. The miniDSP does not have a power switch. We recommend that it simply be left powered on, as power consumption is very low.
5. If you do decide to power the miniDSP 2x4 or kit board off or on, please ensure that you:
 - a. Turn the connected equipment **off** before disconnecting power from the miniDSP, and
 - b. Connect power to the miniDSP before turning connected equipment on.

2.8.2 Notes on modifying the configuration while in offline mode

While in offline mode, the configuration can still be modified in the plugin interface. These changes will of course not be downloaded to the miniDSP 2x4. So:

- When the miniDSP is next put into online mode, selecting the **Synchronize** option will download all changes to the miniDSP hardware unit.
- If you do not wish to have these changes downloaded to the miniDSP hardware unit (for example, you are just fiddling around in the user interface), then make sure that you have saved the configuration to a file *before* making any changes. Then reload the saved configuration before synchronizing again.



The configuration contained in the miniDSP hardware unit cannot be uploaded back to the computer. Therefore, you **must** save your configuration to a file if you wish to recover from any changes you make while in offline mode.

3 PLUGIN ARCHITECTURE AND FEATURES

This section describes the functions available in the plugins. Different plugins have different functions, so each section also includes a note on which plugins support that function.

3.1 SYSTEM SETTINGS

Available in: all plugins

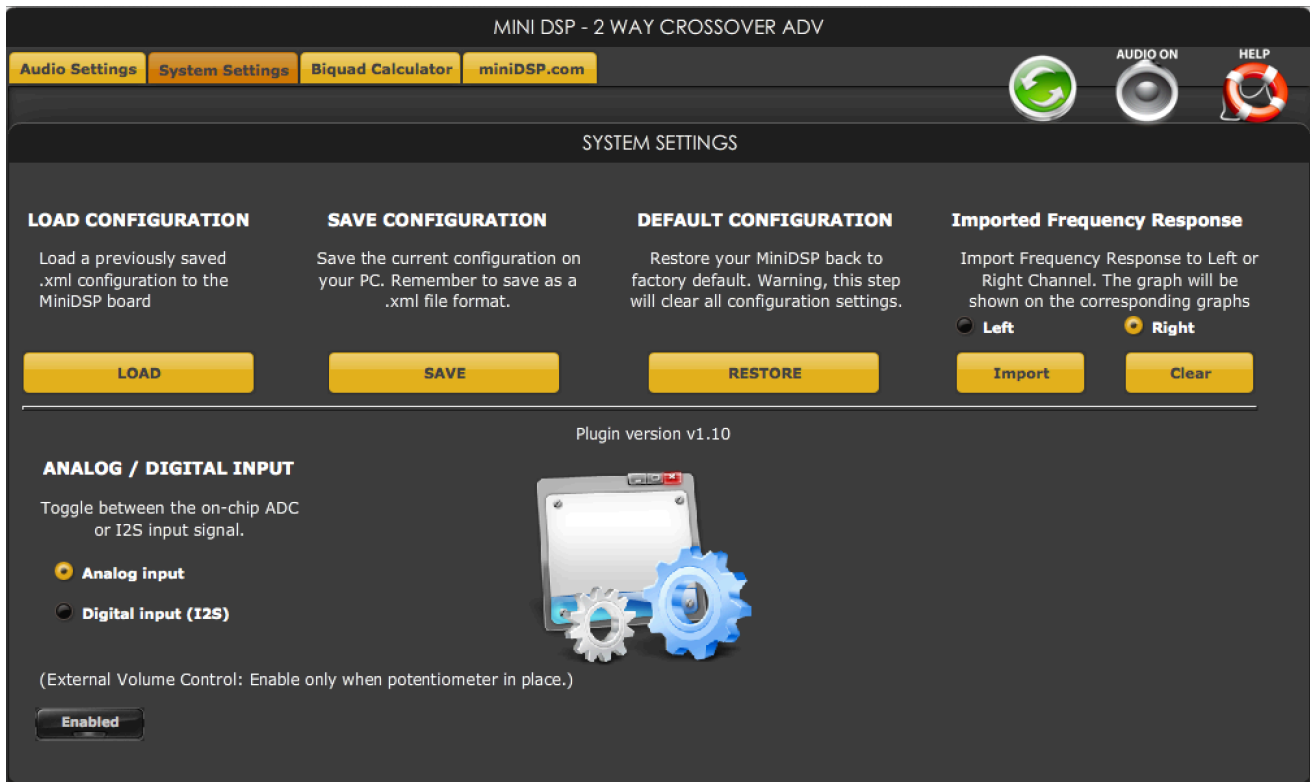

Load Configuration

Loads a configuration file. This changes all the settings to match the settings saved into the file:

- If the plugin is in *online* mode, the configuration settings will be downloaded immediately to the miniDSP hardware unit.
- If the plugin is in *offline* mode, the configuration settings will be downloaded to the miniDSP hardware unit the next time it is put into online mode (provided that the **Synchronize** option is selected from the dialog box).



The configuration file must have been saved with the same plugin. You cannot load a configuration file that was created with a different plugin.



Save Configuration

Saves the current configuration to a file. The file name must end in “.xml” so that the plugin will recognize the file when trying to load it.

Default Configuration

Restore the configuration to the factory default settings.

- If the plugin is in online mode, the defaults settings will be downloaded immediately to the miniDSP hardware unit.
- If the plugin is in offline mode, the default settings will be downloaded to the miniDSP hardware unit the next time it is put into online mode.

Imported Frequency Response

Click on the **Import** button to load a frequency response file. The required file format has, on each line, the frequency and the response magnitude. A maximum of 331 frequency points are allowed. For an example of the file format, go to the **Help** screen and click on the **Import Template** button.

Once the response is loaded, it appears in the frequency response graphs of the relevant PEQ blocks. In the two-way crossovers, the response will be displayed in either the left or right channel, per the selector.

Analog/Digital Input

Selects between analog and digital input. If using the miniDSP kit board with an external data source via I2S (for example, the miniDIGI digital I/O card), setting this to **Digital input** will select the external data source instead of the onboard A/D convertors. If using the miniDSP 2x4, always leave this set to **Analog input**.

External Volume Control

Enables master volume with a potentiometer. With the miniDSP kit board, this option should be enabled if an external volume control potentiometer is connected (see [Volume control](#)). Do not enable this option when using the miniDSP 2x4.

3.2 INPUT SELECTION, LEVEL, AND METERING

Available in: all plugins

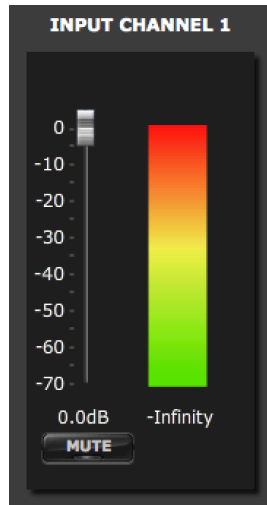

Each input channel has a gain control, together with a level meter (active while the plugin is in online mode), and a mute button.

Level

Adjusts the level on that input channel. In the advanced plugins (**2x4 Advanced, 2Way Advanced, 2Way Advanced 21, 4Way Advanced**), gain adjustments are in increments of 0.1 dB. In all other plugins, gain adjustments are in increments of 1 dB.

Meter

Displays the current input signal level. The level is displayed in dB FS (relative to maximum input voltage). Make sure to keep the input signal below 0 dB FS (red), and keep enough headroom to avoid distortion.

Mute

Mutes the input channel. This is helpful when testing and refining your configuration. (For example, mute each input channel while testing the other channel.)

Most plugins have two input control blocks. The 4-way plugin, **4Way Advanced**, has a single input control block, and an additional control to choose which input to use.

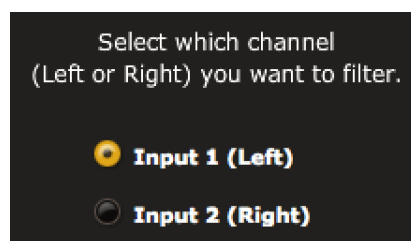

3.3 OUTPUT LEVEL, DELAY, AND METERING

Available in: all plugins

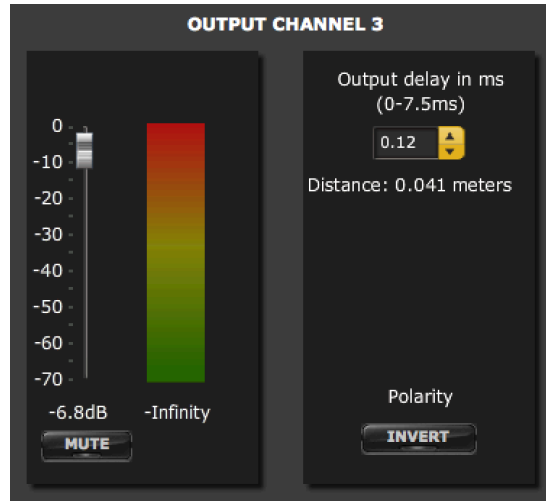

Each output channel has a gain control, together with a level meter (active while the plugin is in online mode), adjustable delay, a mute button and a button for polarity inversion.

Level

Adjusts the level on that output channel. This control is typically used to ensure equal levels on all channels in an active crossover. In the advanced plugins (**2x4 Advanced**, **2Way Advanced**, **2Way Advanced 21**, **4Way Advanced**), gain adjustments are in increments of 0.1 dB. In all other plugins, gain adjustments are in increments of 1 dB.

Meter

Displays the current output signal level. The level is displayed in dB FS – that is, relative to full-scale output voltage, which is 0.9 V RMS. Make sure to keep the signal below 0 dB FS (red), and keep enough headroom to avoid distortion.

Delay

Specifies a delay of up to 7.5 ms on that output channel (4 ms for the **Rear/Center** plugin). This is used to time-align drivers in an active speaker system, to adjust the timing of specific channels to match other speakers, or to adjust relative phase for better subwoofer integration. When a delay is set, the plugin also displays the equivalent distance – that is, the distance that sound travels in the given time.

Mute

Mutes that output channel. This is helpful when testing and refining your configuration. (For example, mute the tweeter to test the woofer, and vice versa.)

Polarity

Inverts the polarity of the output channel. In crossover applications, some slopes (e.g. 12 dB/octave) typically require that one of the output channels be inverted. In subwoofer applications, this can be helpful to improve integration with the main speakers.

The **Rear/center channel** plugin has an additional delay block that applies to both output channels. A delay of up to 27 ms can be set:

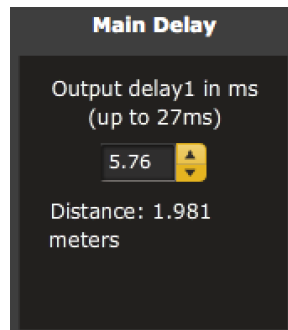

3.4 GRAPHIC EQ

Available in: **Rear/Center**

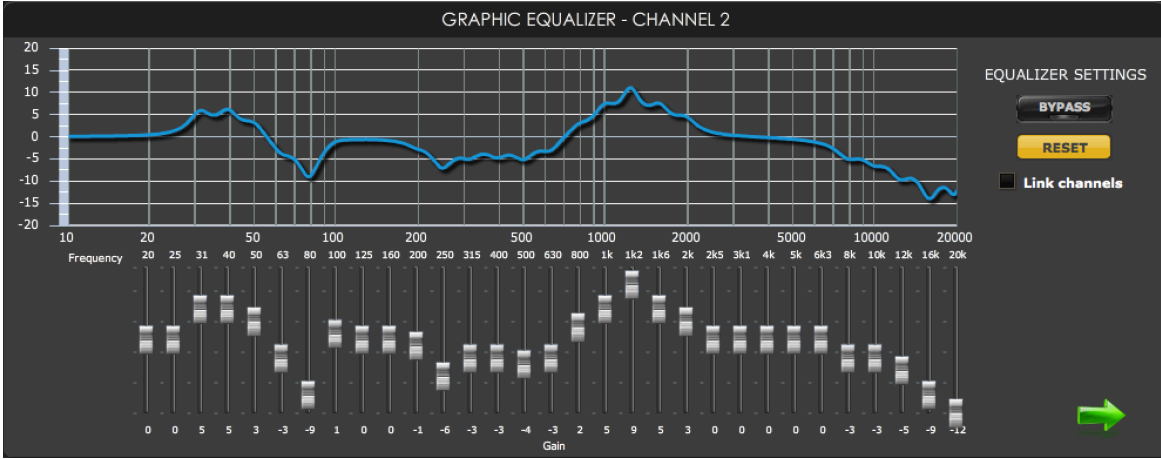

The graphic equalizer block (GEQ) presents a 31-band, 1/3rd octave EQ, similar to a “traditional” analog EQ. The top section shows the overall response curve of all EQ bands. Hovering the mouse over the curve brings up an overlay with the frequency and gain at that frequency.

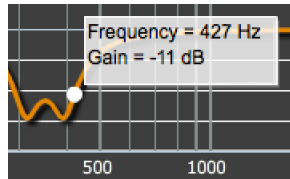

Control sliders

The sliders in the lower half of the control panel adjust the boost or cut of the signal around that frequency. The maximum control range is +/- 12 dB.

Bypass

Clicking on the **Bypass** button disables the graphic EQ processing.

Reset

Clicking the **Reset** button resets all sliders to 0 dB.

Link channels

If selected, the slider positions are applied to both audio channels.

3.5 PARAMETRIC EQ

Available in: **2x4 Advanced, 2Way Advanced, 2Way Advanced 21, 4Way Advanced**

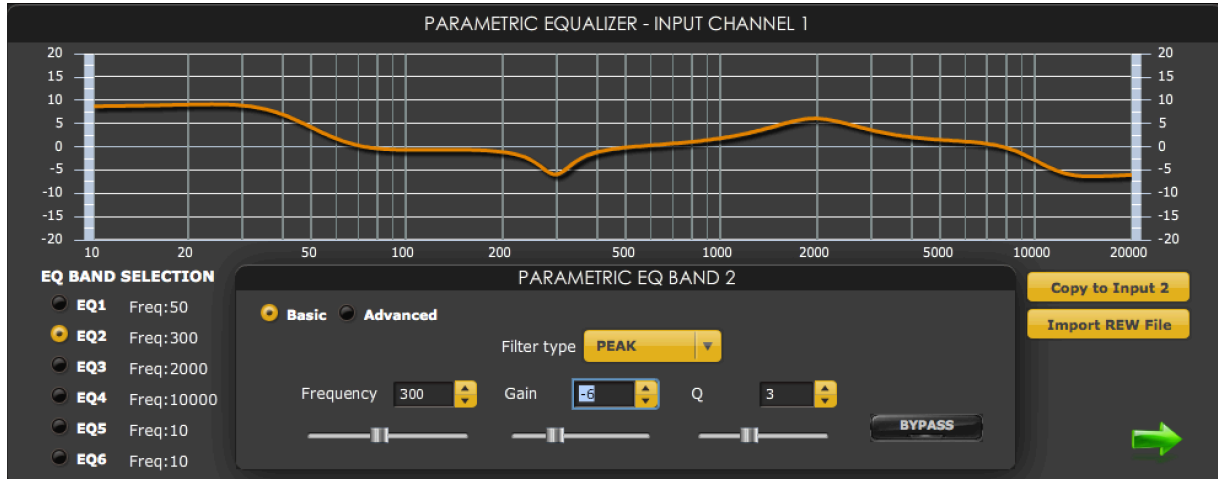

The parametric EQ (PEQ) block provides six parametric filters, each of which can be set for a peaking or notch filter, high shelf filter, and low shelf filter.

The top section of the control panel shows the overall response curve of all six PEQ filters. Hovering the mouse over the curve brings up an overlay showing the frequency and the gain at that frequency.

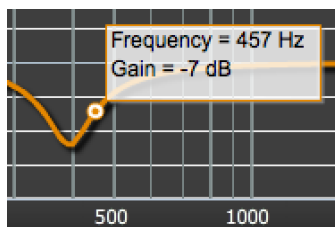

The example above shows (by way of example, this is not a typical setting) a response curve with four filters:

- A low-shelf filter with 6 dB boost, centered at 50 Hz
- A peaking filter with 6 dB cut (gain set to a negative value), centered at 300 Hz
- A peaking filter with 6 dB boost, centered at 2 kHz
- A high-shelf filter with 6 dB cut (gain set to a negative value), centered at 10 kHz

EQ band selection

Click on the radio buttons **EQ1**, **EQ2**, etc. to display the parameters for that filter.

Basic/Advanced

By default, each filter is in basic mode, and shows the controls described below. Advanced mode enables custom biquad programming for almost infinite flexibility in filter implementation. This is described in [Custom biquad programming](#).

Filter type

Selects the type of filter:

- PEAK** Create a dip or a peak in the frequency response.
- LOW_SHELF** Reduce or increase part of the frequency spectrum *below* a given frequency.
- HIGH_SHELF** Reduce or increase part of the frequency spectrum *above* a given frequency.

Frequency

For the PEAK filter type, this is the center frequency of the peak or dip. For the HIGH_SHELF and LOW_SHELF filter types, this is the frequency at which the gain is half of the set value.

Gain

For the PEAK filter type, this is the gain in dB at the center frequency. For the HIGH_SHELF and LOW_SHELF filter types, this is the gain in dB reached at high or low frequencies respectively. A filter has no effect if its gain is set to 0. Gain can be adjusted in increments of 0.1 dB up to +/- 16 dB.

Q

Q controls the “sharpness” of the filter. For the PEAK filter type, lower Q gives a shallower peak or dip, while higher Q gives a narrower peak or dip. For the HIGH_SHELF and LOW_SHELF filter types, Q controls how quickly the filter transitions from no gain to maximum gain.

Bypass

Clicking on the **Bypass** button disables that filter. (All other filters are still operational unless individually bypassed.)

Copy to...

Clicking this button copies all of the filter settings to the corresponding PEQ block in the other channel.

Import REW File

This button selects a file exported from Room EQ Wizard’s automatic equalization function. For more information, see the app note [Auto-EQ tuning with REW](#) and the section [Custom biquad programming](#).

3.6 CROSSOVER

Available in: 2x4 Advanced, 2Way Advanced, 2Way Advanced 21, 4Way Advanced

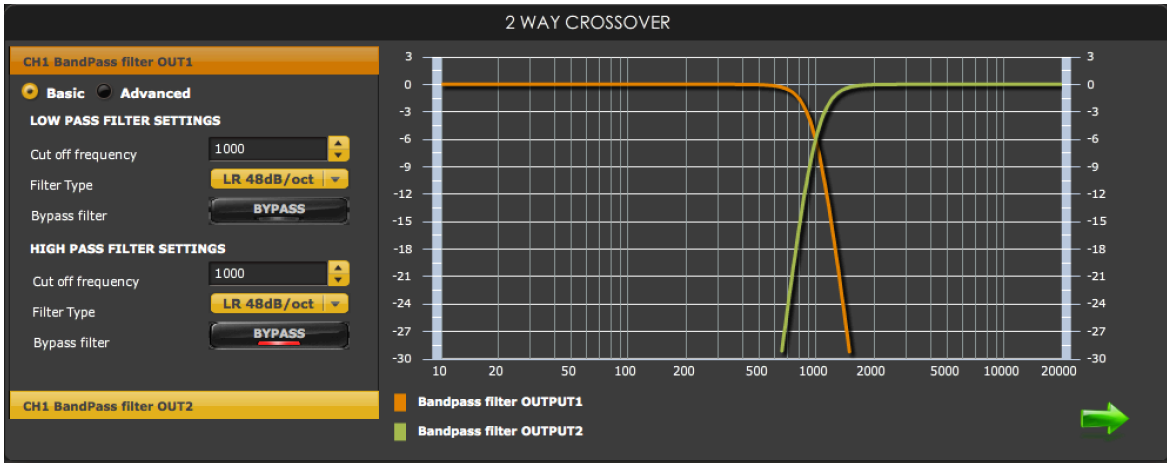

Crossovers “split” the frequency band to send to different drivers. In a two-way loudspeaker, for example, a *low pass* filter is used to remove high frequencies from the signal sent to the woofer, and a *high pass* filter is used to remove low frequencies from the signal sent to the tweeter. The above screenshot shows a two-way crossover. In a four-way crossover, the signal is split into four frequency bands:

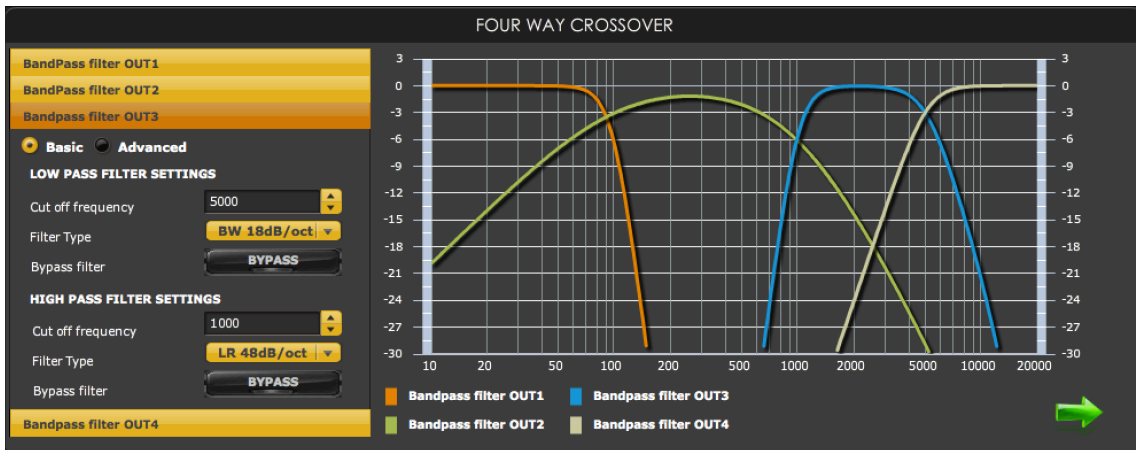

In the miniDSP 2x4 plugins, each output channel has a high pass filter and a low pass filter, each of which can be set to one of a range of filter types and slopes, or individually bypassed. Clicking on the bars labeled “CH1 Bandpass Filter OUT1,” and so on displays the filter parameters for that output channel.

Unlike conventional analog crossovers, the flexibility of DSP allows a completely arbitrary mix of different filter slopes and types. Filters can be set at any frequency, or even disabled completely. This allows maximum flexibility in matching your crossover to the acoustic characteristics of the loudspeaker drivers that you are using.

The graph at the right of the display shows the frequency response of the output channels. Hovering the mouse over the curve brings up an overlay showing the frequency and the attenuation at that frequency.

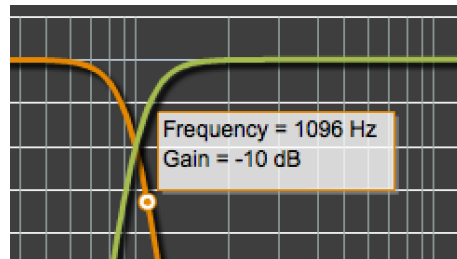

Basic/Advanced

BY default, the crossover is in basic mode, and shows the controls described below. Advanced mode enables custom biquad programming for almost infinite flexibility in crossover filter implementation. This is described in [Custom biquad programming](#).

Cutoff Frequency

Sets the nominal cutoff frequency of the crossover. In actual fact, of course, the crossover has a more or less gradual transition from “full on” to “full off,” as determined by the filter slope.

Filter type

Selects the type and slope of the filter. The steeper the slope, the more quickly frequencies above or below the cutoff frequency are attenuated. There are three types of filter:

Butterworth (BW)

Available in 6, 12, 18, 24, 30, 36, 42, and 48 dB/octave, Butterworth crossover filters are 3 dB down at the cutoff frequency.

Linkwitz-Riley (LR)

Available in 12, 24, and 48 dB/octave, Linkwitz-Riley crossover filters are 6 dB down at the cutoff frequency.

Bessel

Available in 12 dB/octave only, a Bessel filter gives a more gradual roll-off through the crossover region.



The **Stereo Graphic EQ** is limited to 12 dB/octave Butterworth, 12 dB/octave Bessel, and 24 dB/octave Linkwitz-Riley.

Bypass

Clicking on the **Bypass** button disables that high pass or low pass filter. (All other crossover filters are still operational unless individually bypassed.)

3.7 HIGH PASS AND LOW PASS FILTERS

Available in: **Rear/Center channel**

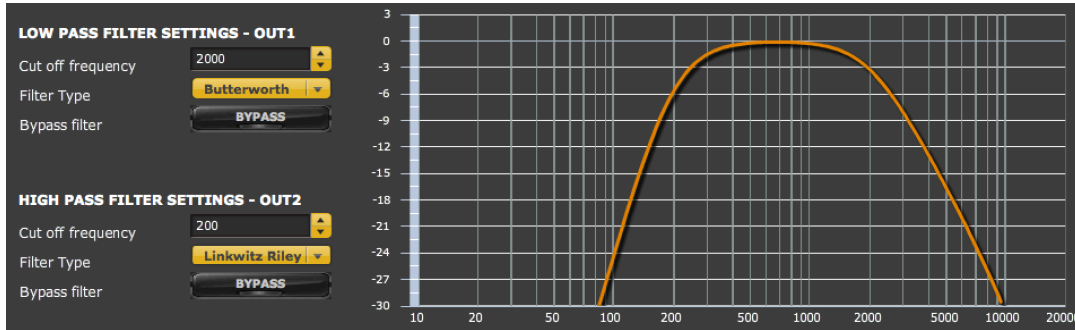

High pass and low pass filters are a subset of crossover functionality. These blocks have a single input and a single output. Each filter can be individually set to one of the available filter types, or bypassed. The filter types are:

- Butterworth 12 dB/octave
- Bessel 12 dB/octave
- Linkwitz-Riley 24 dB/octave

3.8 MONO/STEREO MODE

Available in: **2Way Advanced 21**

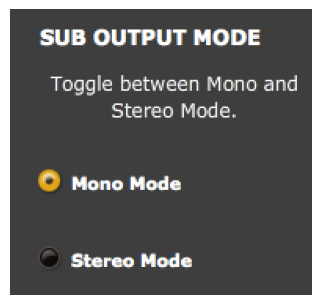

The **2Way Advanced 21** plugin supports mixing of two output channels, allowing this plugin to be used in “2.1” applications where a mono subwoofer signal is derived from a stereo signal. To access this selection, click on the **System Settings** tab.

In **Mono Mode**, output channels 1 and 2 will be mixed together. Note that mixing occurs at the end of the signal processing chain, so usually you will need to use the **Copy** function to copy settings from channel 1 to channel 2. In **Stereo Mode**, the two output channels are independent – that is, the plugin behaves as a two-way crossover.

3.9 KEYBOARD SHORTCUTS

The miniDSP 2x4 plugins support the use of the keyboard for many operations.

Tab

The Tab key moves the focus to the next user interface element. A light blue surrounding box indicates the user interface element with the focus if it is a text entry box, a button, or a block in the signal flow diagram. Shift-Tab moves the focus in the opposite direction.

Up/down arrows

The up/down arrow keys adjust the value of the parameter with the focus. For example:

- Input and output channel gain
- Crossover frequency and filter type
- PEQ filter frequency, gain, and Q

Space

The Space bar toggles buttons that have two states, such as **Bypass**, **Invert**, and **Mute**. If the light blue highlight is one of the blocks in the signal flow diagram, then the Space bar will open the control panel for that block.

Keyboard shortcuts are helpful for making rapid or fine adjustments. For example, in the input and output controls blocks of the advanced plugins, click on the gain slider, then on the Up and Down arrow keys to adjust the gain in 0.1 dB increments.

3.10 CUSTOM BIQUAD PROGRAMMING

Available in: **2x4 Advanced, 2Way Advanced, 4Way Advanced, 2Way Advanced 21**

Custom biquad programming is available in the PEQ and Crossover blocks of the *Advanced* plugins. Its purpose is to allow you to directly provide the low-level parameters aka *biquad coefficients* that control the digital filters of the miniDSP, thus providing an almost infinite degree of flexibility.

For example, you can create hybrid crossovers with more than one cutoff frequency, create crossover filter types beyond those provided in the easy-to-use “basic” interface, implement a Linkwitz transform, or mix crossover and filtering biquads in the same block.

3.10.1 What’s a “biquad”?

A biquad is the basic unit of processing that is used to create digital filters. It can be described either with an equation or with a signal flow diagram, as shown here:

$$H(z) = \frac{b_0 + b_1 z^{-1} + b_2 z^{-2}}{1 + a_1 z^{-1} + a_2 z^{-2}}$$

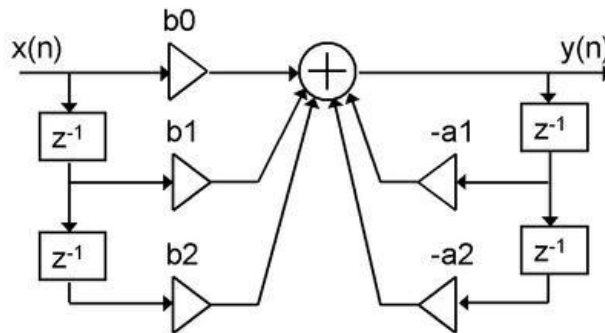

A single biquad like this can perform a great many functions, including all of the functions of a single parametric EQ filter, one 6 or 12 dB/octave high pass or low pass filter, and more. Biquads are combined in series (cascaded) to create more complex filters. The function that each biquad performs is determined by just five numbers: a_1 , a_2 , a_0 , b_1 , and b_2 . These numbers are called the *coefficients*.

3.10.2 Using custom biquad programming

If the plugin supports custom biquad programming, each crossover block or PEQ filter has a selector that switches it to advanced mode:

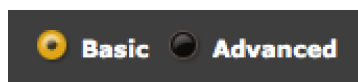

In advanced mode, the biquad coefficients are pasted directly into the user interface. These coefficients must be calculated using a filter design program – see the following sections for suggestions.

Parametric EQ advanced mode

In the parametric EQ blocks, advanced mode allows each individual filter to be specified by its coefficients. After pasting in the biquad coefficients, click on the **Process** button for them to take effect.

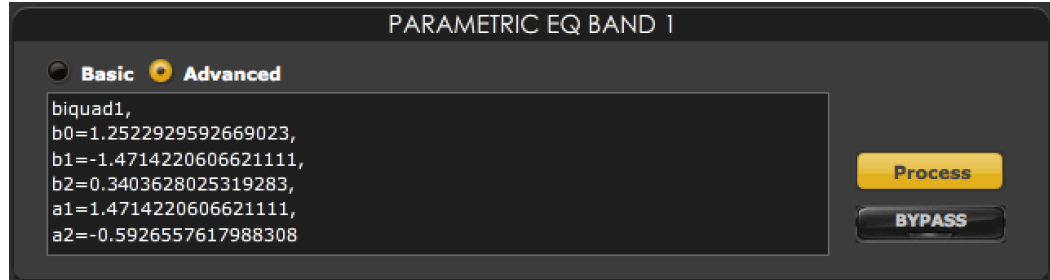

Parametric EQ file import (REW integration)

All six filters can be set at once by importing a coefficient file from Room EQ Wizard (REW). See [Room EQ Wizard](#) below.

Crossover advanced mode

The **Crossover** blocks have eight biquads on each output channel, allowing a high pass and low pass filter of up to 48 dB/octave in **Basic** mode. In **Advanced** mode, all eight biquads need to be specified. After pasting in the biquad coefficients, click on the **Process** button for them to take effect.

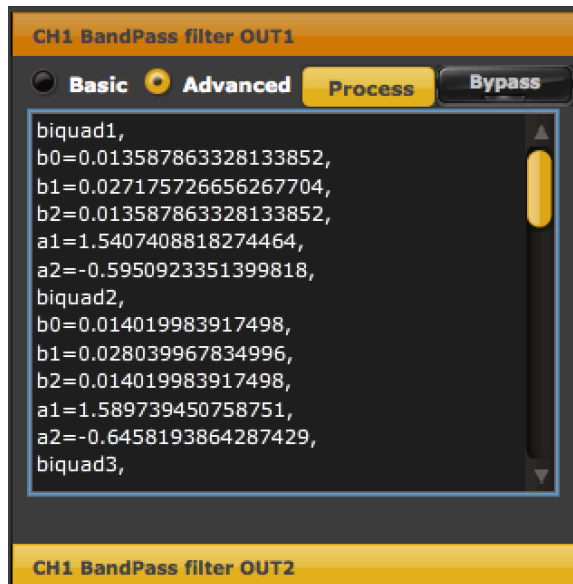

For a cut-and-paste example of the biquad format, click on the **Help** button and then the **Crossover Input Format** button.

3.10.3 The plugin calculator

Plugins that support custom biquad programming include a basic biquad coefficient calculator. Click on the **Biquad Calculator** tab to access it.

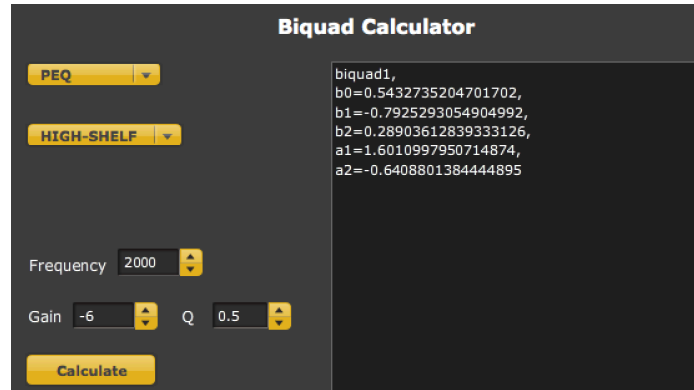

The calculator supports single parametric EQ bands, as shown in the above screenshot. To use the calculated biquad, simply copy the coefficients into the PEQ filter (set to Advanced mode) and click on the **Process** button.

When calculating a crossover filter, the calculator will produce four biquads for the low pass filter, and four for the high pass filter. Paste each set into the crossover input screen (set to Advanced mode), and click on the **Process** button.

3.10.4 Biquad calculation spreadsheet

The community-developed biquad calculation spreadsheet allows more filter types to be calculated, including notch filters, Linkwitz transforms, and filters with arbitrary Q-factor. Access this spreadsheet here (requires Microsoft Excel):

- http://www.minidsp.com/images/fbfiles/files/All_digital_coefs_v1-20101026.zip

3.10.5 Room EQ Wizard (REW)

Room EQ Wizard is a free acoustic measurement and analysis tool, available for Windows, Mac and Linux platforms. It includes the ability to automatically generate a bank of parametric EQ biquads based on a measurement. These coefficients can be saved to a file from REW and loaded directly into a PEQ bank in a miniDSP plugin.

Room EQ Wizard can be downloaded here:

- <http://www.roomeqwizard.com/#downloads>

For guidance on using this feature, please refer to the app note [Auto EQ with REW](#).

3.10.6 Active Crossover Designer (ACD)

Active Crossover Designer (ACD) by Charlie Laub performs the complete set of functions for active crossover design and generates biquad coefficients as its output. Download it here (requires Microsoft Excel):

- <http://audio.claub.net/software/ACD/ACD.html>

4 OPTIMIZING GAIN STRUCTURE

When deploying a DSP solution in your audio system, a topic that becomes more important than with analog equipment is *gain structure*. This means that the signal levels throughout the system should be set to an optimum – high enough to maximize digital resolution and minimize noise, but not so high as to result in clipping and distortion.

The miniDSP 2x4 and kit board include a jumper to select their input sensitivity, allowing them to be used in a wider variety of systems.

When purchased, the miniDSP 2x4 is provided in either “A” (0.9 VRMS maximum input level) or “B” (2.0 VRMS maximum input level) versions, but it can be converted between them by opening the case and moving two jumpers.

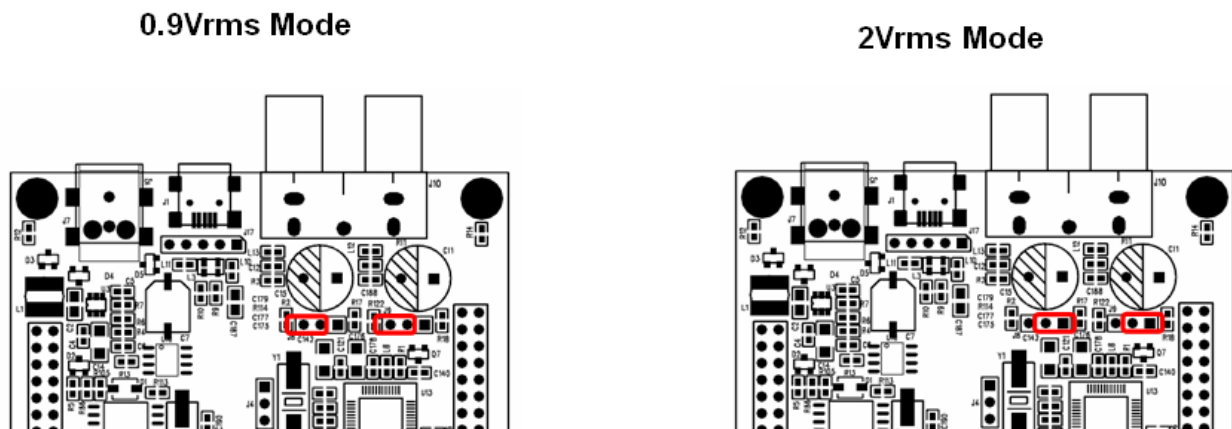

A (0.9 V) position

The maximum input signal voltage allowed before clipping the A/D converter is 0.9 Volts RMS. This position is typically used when the miniDSP is connected between a preamp and a power amplifier or power amplifiers.

B (2.0 V) position

The maximum input signal voltage allowed before clipping the A/D converter is 2.0 Volts RMS. This position is typically used when the miniDSP is connected directly to a source without volume control, such as a CD player.

Note that the input sensitivity jumper setting does not affect the maximum output signal – it is always 0.9 V RMS. Therefore, when the jumper is in the 2.0 V position, the miniDSP (without any other processing enabled) has an approximately 7 dB insertion loss. If higher output signal levels are required, then the [miniDSP Balanced 2x4](#) or the [4x10 Hd](#) can be used.

For more information on gain structure, see the app note [Gain Structure 101](#).

5 KIT DOCUMENTATION

The miniDSP kit is a bare circuit board that can be incorporated into your own chassis and combined with other electronics components. This section documents the supported connectivity and configuration of the kit board.

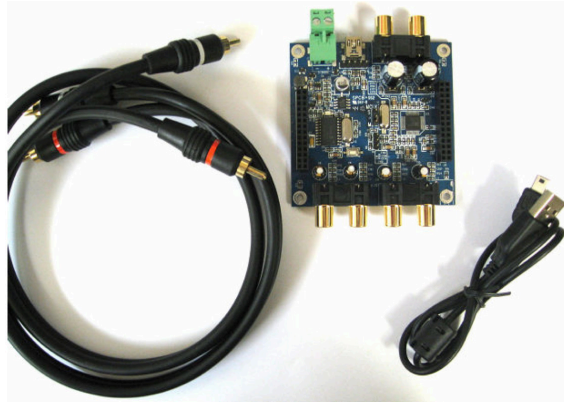

5.1 BOARD LAYOUT AND FEATURES

This diagram shows the key features of the board.

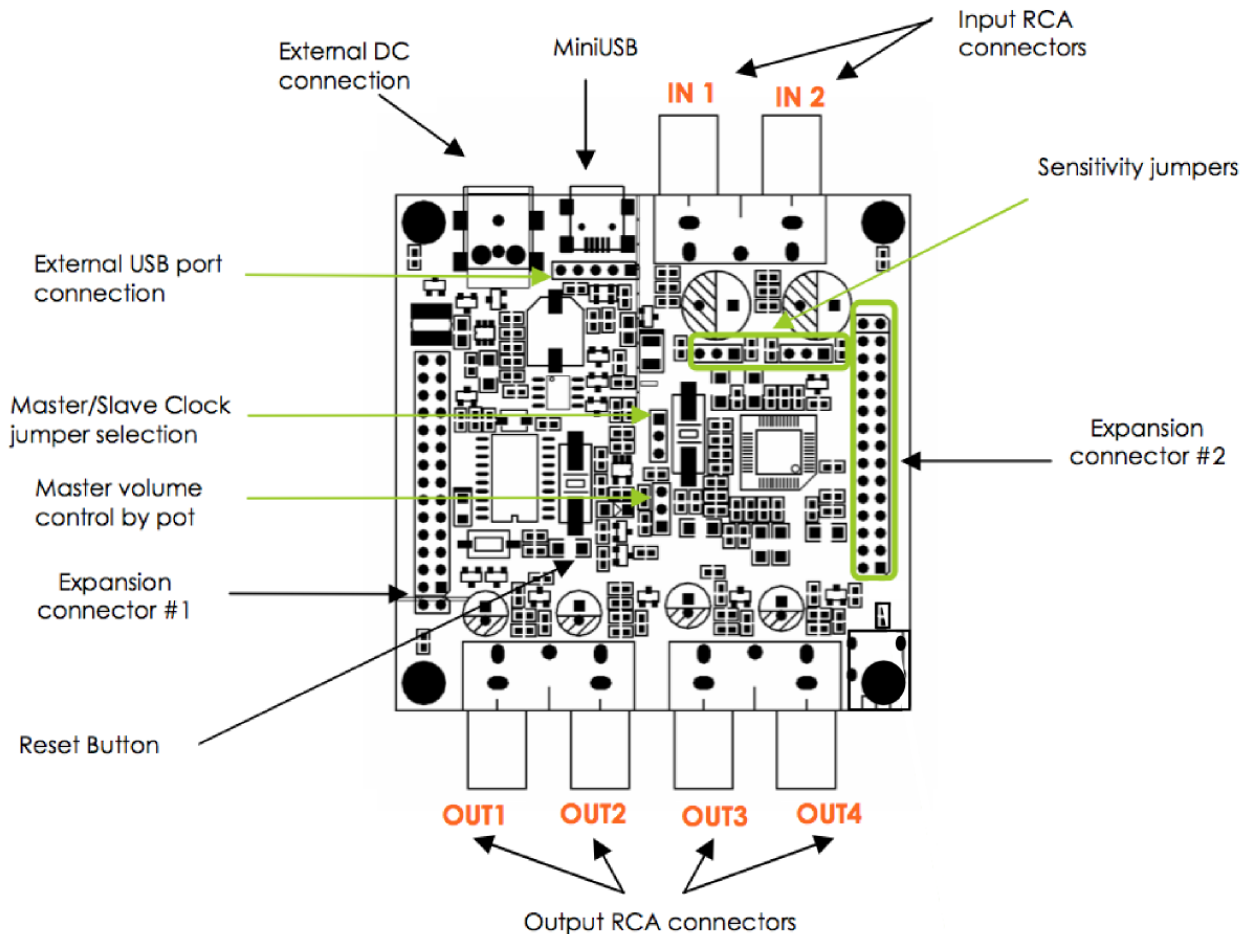

5.2 EXPANSION HEADER AND I2S CONNECTIVITY

The expansion header #2 is available for expansion purposes. It carries, in addition to power and ground, the full set of analog signals and the digital equivalents in I2S format. The pinout of this header is shown below.

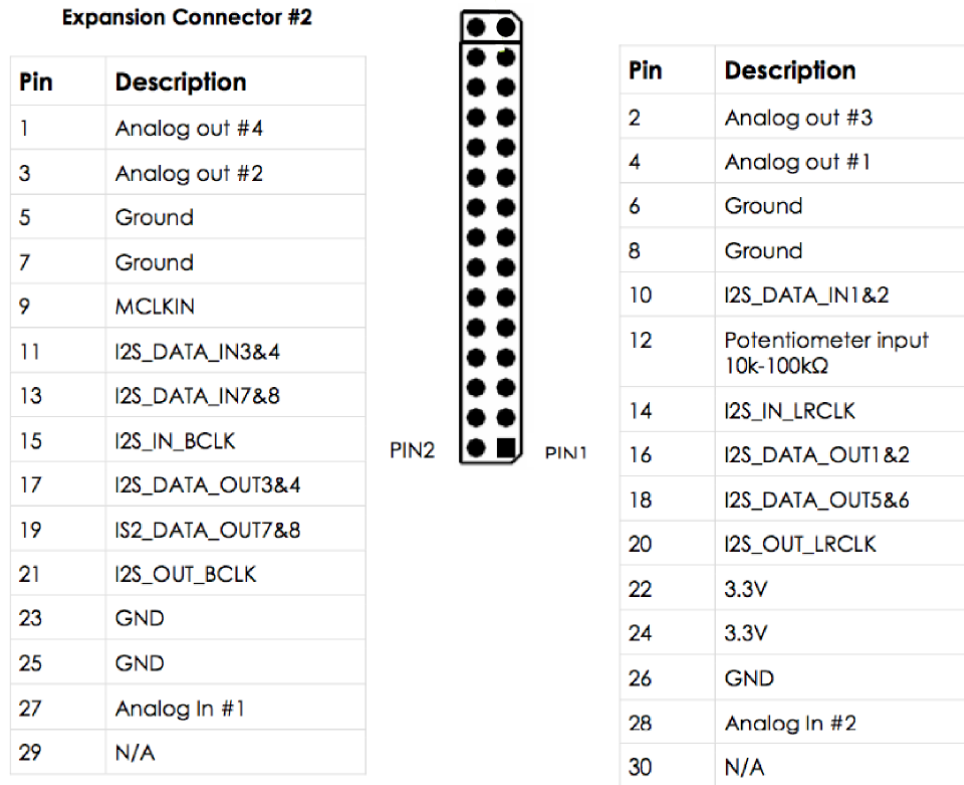

I2S, also known as Inter IC Sound, is an electrical serial bus used to interface digital audio devices at the chip and circuit board level. Note that I2S is not a “plug and play” protocol, and requires attention to technical details such as clocking and wire layout. It is a solution that we make available for *advanced* DIYers with suitable knowledge, skills and measurement equipment to use it.

For more information, please read the [I2S technical note](#) available in the download section of our website.

5.3 USB CONNECTIVITY

The miniDSP kit board has a 5-pin header (standard 0.1"/2.54mm pitch) located just behind its on-board USB connector, for use in builds requiring a panel mount USB connector.

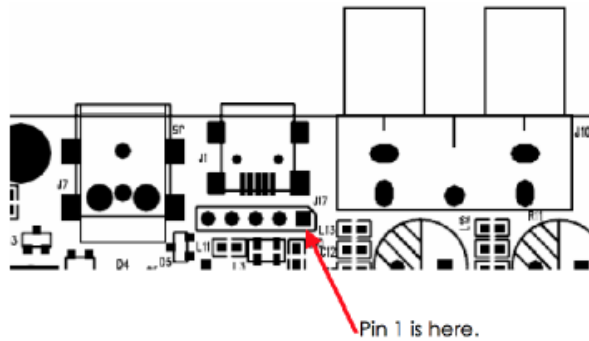

- Pin 1: Vcc (+5 V)
- Pin 2: D-
- Pin 3: D+
- Pin 4: Gnd
- Pin 5: Gnd

This header will interface to common off-the-shelf cable assemblies (typically used in computer hardware). Although this is a standard connector, you should nonetheless confirm the pin-out with the manufacturer, or you could easily cause damage to your computer or miniDSP kit. In most cases, pins 4 and 5 can be identified by a black wire, but once again, DO check the manufacturer's spec of the connector to prevent any short-circuits.



To make things simple, we provide a suitable cable for purchase in the accessories section of our [website](#).

5.4 BYPASS/RESET

A reset button is available on board and will bypass all processing by the DSP IC. If pressed once, the onboard LED will stop flashing, indicating that processing has stopped and that the miniDSP is in reset mode. To initialize the DSP, press the button again and the DSP will return to normal processing (LED flashing).

While it is a handy feature to test certain configurations, beware that in DSP bypass mode, audio inputs 1 and 2 are routed directly (straight through) to outputs 3 & 4. We therefore recommend not pressing the reset button unless you know exactly what you are about to do.

5.5 VOLUME CONTROL

Master volume control of all output channels can be accomplished with a 10 kΩ linear potentiometer connected to the designated 3-pin header (standard 0.1"/2.54mm pitch). The wiring diagram for the potentiometer is shown in the diagram below. No attenuation (maximum volume) is applied when pin 2 of the header is at 3.3 V, while maximum attenuation (minimum volume) is applied when pin 2 is at 0 V.

For your convenience, a suitable potentiometer already wired to a 3-pin female connector can be purchased together with the kit board, or separately from the Accessories section of our [website](#).

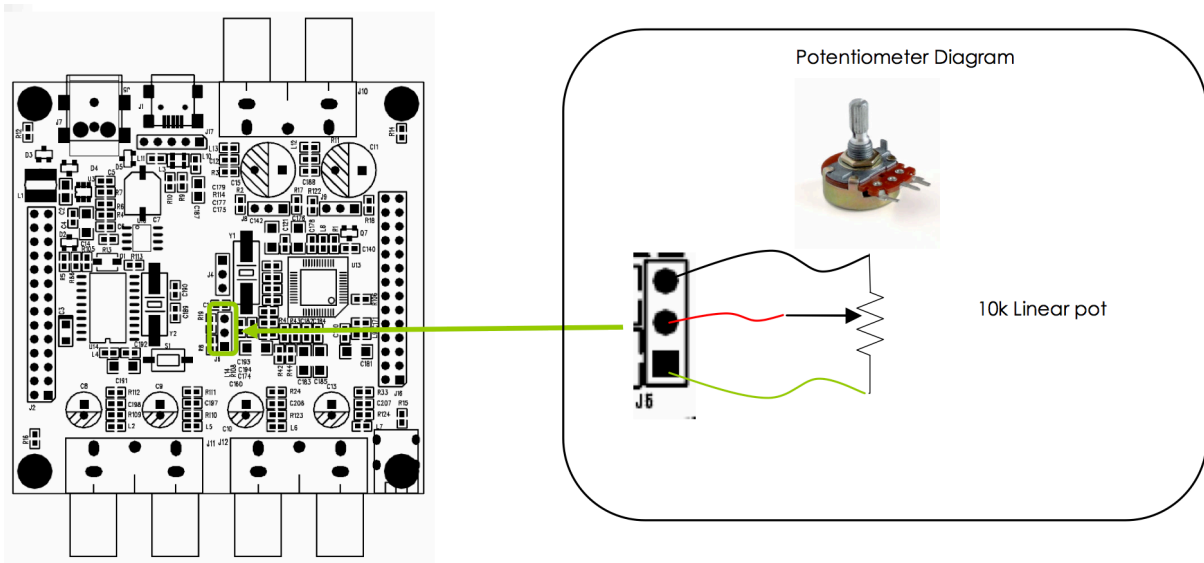

The connection to the volume header must be performed with the board powered down. If your volume control operates in reverse i.e. volume decreases as the pot is rotated clockwise, turn off connected equipment, remove power from the miniDSP board, and reverse the connector.

A single potentiometer can be connected to multiple miniDSP kit boards. This allows master volume control of eight or more output channels. This diagram illustrates the wiring for master volume control of multiple boards:

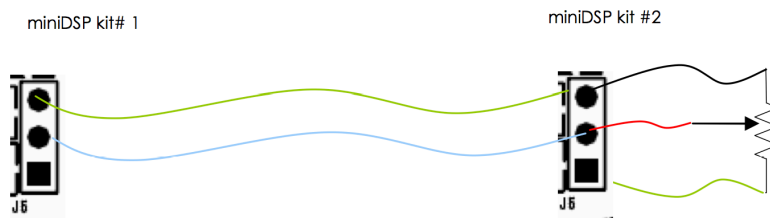

Finally, to enable the master volume control, use the **Enable** button in the **System settings** tab of the plugin user interface. (This *must* be disabled if no potentiometer is in place.)

5.6 MASTER/SLAVE MASTER CLOCK SELECTION

The MCLK jumper, located in the center of the board, selects the source of the master clock:

- If the board is used standalone, it generates its own master clock. In this case, the jumper must be in the **Master** position.
- If the board is used with an external device that generates the I2S signals, the board must slave to the external clock. In this case, the jumper must be in the **Slave** position.

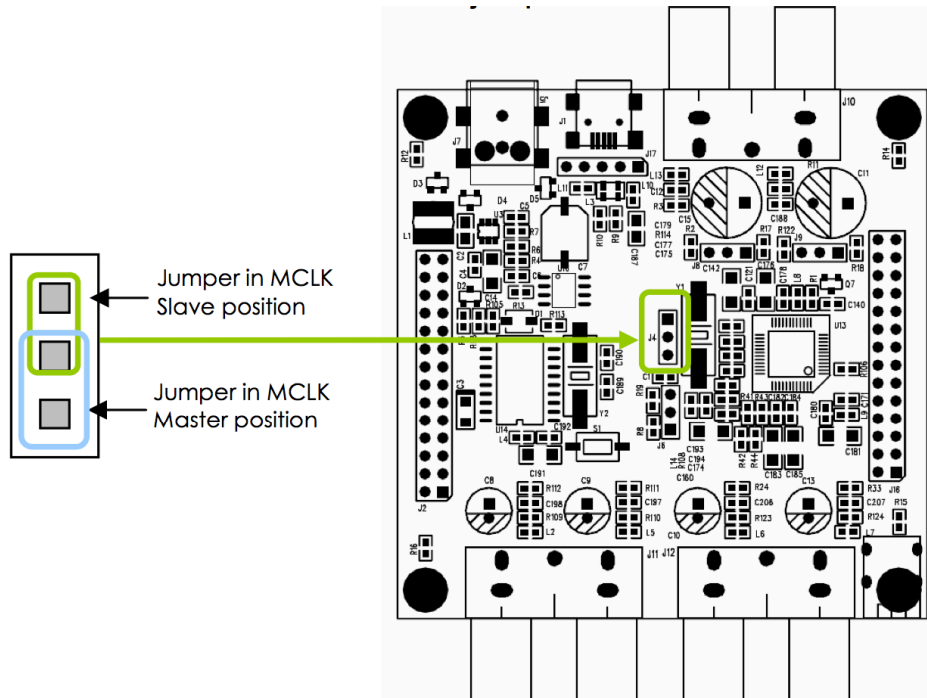

5.6.1 Examples

Board used standalone or with miniAMP only

Set jumper to **Master**.

Board used with miniDIGI, or with miniDIGI+miniAMP

Set jumper to **Slave**.

Board used with USB interface and direct I2S connection

Set jumper to **Slave**.

6 ADDITIONAL INFORMATION

6.1 SPECIFICATIONS

Computer connectivity	Driverless USB 2.0 control interface
Digital Signal Processor	28/56 bit Digital Signal Processor Engine, double-precision internal processing
ADC/DAC resolution and sample rate	24-bit, 48 kHz
Analog Audio Input	Unbalanced RCA
Maximum input level, <1% THD	0.9 VRMS (RevA) or 2.0 VRMS (RevB)
ADC dynamic range, un-weighted	> 98 dB
Input impedance	6 k Ω
Analog Audio Output	Unbalanced RCA
Maximum output level, <1% THD	0.9 VRMS (2.5 Vp-p)
DAC dynamic range, un-weighted	> 98 dB
Output impedance	560 Ω
Certification	CE / FCC certified - ROHS compliant
Power supply	USB-powered, or 4.5 – 24 VDC @150 mA via 2.1mm center-positive
Dimensions (H x W x D)	27 x 107 x 110 mm

6.2 TROUBLESHOOTING

The following table lists the most common causes of issues with the miniDSP 2x4. If following this table does not provide a solution, see [Obtaining Support](#) below.

Item#	Symptoms	Troubleshooting recommendation
1	Cannot install software	a. Confirm that you downloaded and installed the required frameworks first (see Download and install the plugin).
2	Cannot connect to the board	a. If using an external DC supply, try connecting with USB power only.
3	“Missing biquad” error	a. Quit the plugin. b. In the My Documents (or Documents on the Mac) folder, locate the miniDSP folder, and within it the folder with the plugin name. Delete this folder. c. Restart the plugin. d. Reload your saved configuration.
4	Cannot load a configuration	a. Confirm the format of your file (.xml). b. Check that you are loading a file saved with the same plugin.
5	No audio on outputs	a. Check the input meters are showing signal (if not, see item 6) b. Check that master mute is not enabled c. Check that the mute buttons in the output control blocks are not enabled d. [Crossover plugins only] Check that your crossover frequencies are correct e.g. that you don’t have high pass and low pass frequencies incorrectly set.
6	No signal showing on input meters	a. Check that the mute buttons in the input control blocks are not enabled. b. Check that your source is playing audio. c. Check that your source is not muted and is not playing at too low a level (e.g. volume control).
7	Audio sounds distorted	a. Check the input meters and ensure that you are not overloading the inputs. If necessary, reduce the signal level from the source or switch the miniDSP to 2V input. b. Check the output meter and ensure that you are not overloading the outputs. If necessary, reduce the output gain and/or the amount of boost in the EQ blocks.



6.3 OBTAINING SUPPORT

1. Check the [forums](#) on miniDSP.com to see if this issue has already been raised and a solution or solutions provided.
2. Contact miniDSP via the support portal at [minidsp.desk.com](#) with:
 - a. The specific product you are having an issue with.
 - b. A clear explanation of the symptoms you are seeing.
 - c. A description of the troubleshooting steps (see [Troubleshooting](#) above) you performed and the results obtained.