

# 10" Subwoofer Starter Kit

Thank you for purchasing the 10" Subwoofer Starter kit. The included parts in this kit were precision cut using CNC machinery for the best possible fit and finish. With a little time and patience, your finished product will provide years of low frequency bliss. Please follow the following instructions for the best possible results.

## Suggested tools and consumables:

3/4" Medium Density Fiberboard (MDF)

Wood clamps (you can never have too many of these)

Sanding block and/or electric finishing sander

Binding post/terminal cup

Circular saw/Table Saw

Wood glue/Polyurethane glue

Rag or paper towels

Speaker or hook-up wire

First, empty the contents of the package, inspect the parts to ensure everything has been included and is in good condition. Before gluing anything, do a dry fit of the included parts to familiarize yourself with the parts and their assembly. This will also give you a chance to ensure that all pieces have been cut properly. If any parts are missing or damaged please contact our customer service department at 1-800-338-0531.

- 1) Set the enclosure parts out on a flat level surface and ensure that all pieces are free of dust and debris.
- 2) Glue all mating surfaces of the brace components and assemble as shown. Apply enough pressure to ensure glue is spread through each joint (some glue squeeze-out can be expected).

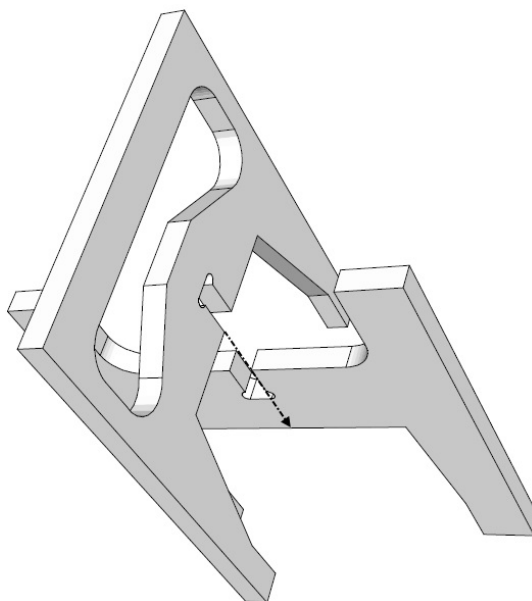

- 3) Glue all mating surfaces of the brace assembly and primary baffle then assemble as shown. Make sure that the brace assembly is centered on the primary baffle. Apply enough pressure to ensure glue is spread through each joint (some glue squeeze-out can be expected).

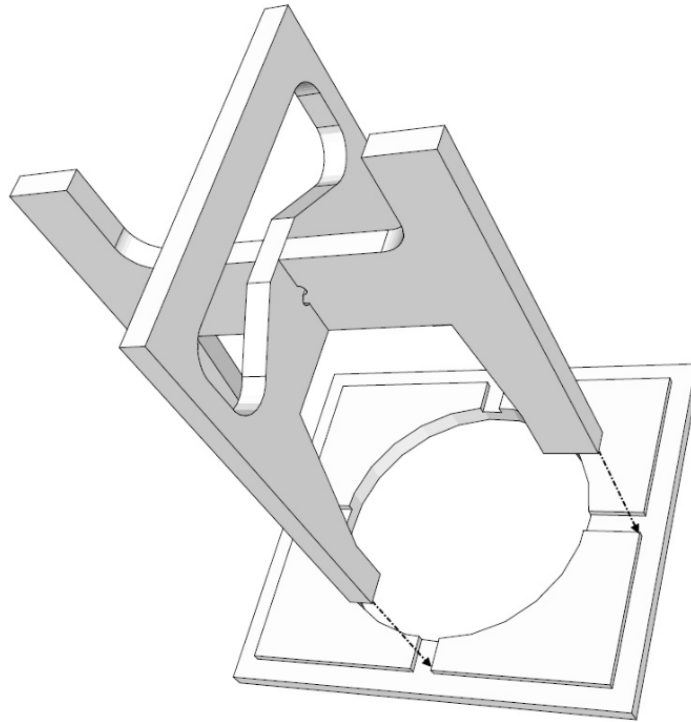

- 4) Evenly spread a thin layer of glue to the back side of the secondary baffle and assemble as shown. Make sure that the secondary baffle is centered on the primary baffle. Clamp baffle and brace assembly together so that even pressure is applied to all glued surfaces. Using a damp rag or paper towel, wipe away any glue squeeze-out from between the baffles and inside the rabbeted edges. Allow to dry according to the glue manufacturer's recommendations and remove clamps.

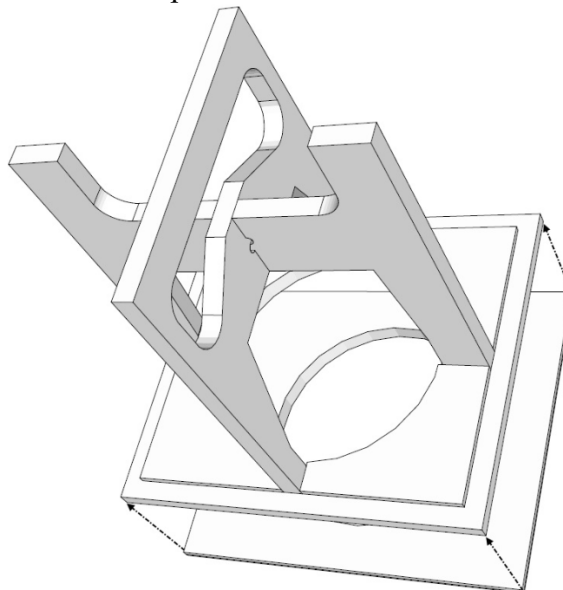

- 5) This completes the assembly of the included components. The sides and the back of the enclosure need to be cut to the following dimensions using 3/4" thick material (MDF is recommended) before continuing to the next step:

**Sides:**

4 pieces at 13" by 13"

**Back:**

1 piece at 13" by 14.5"

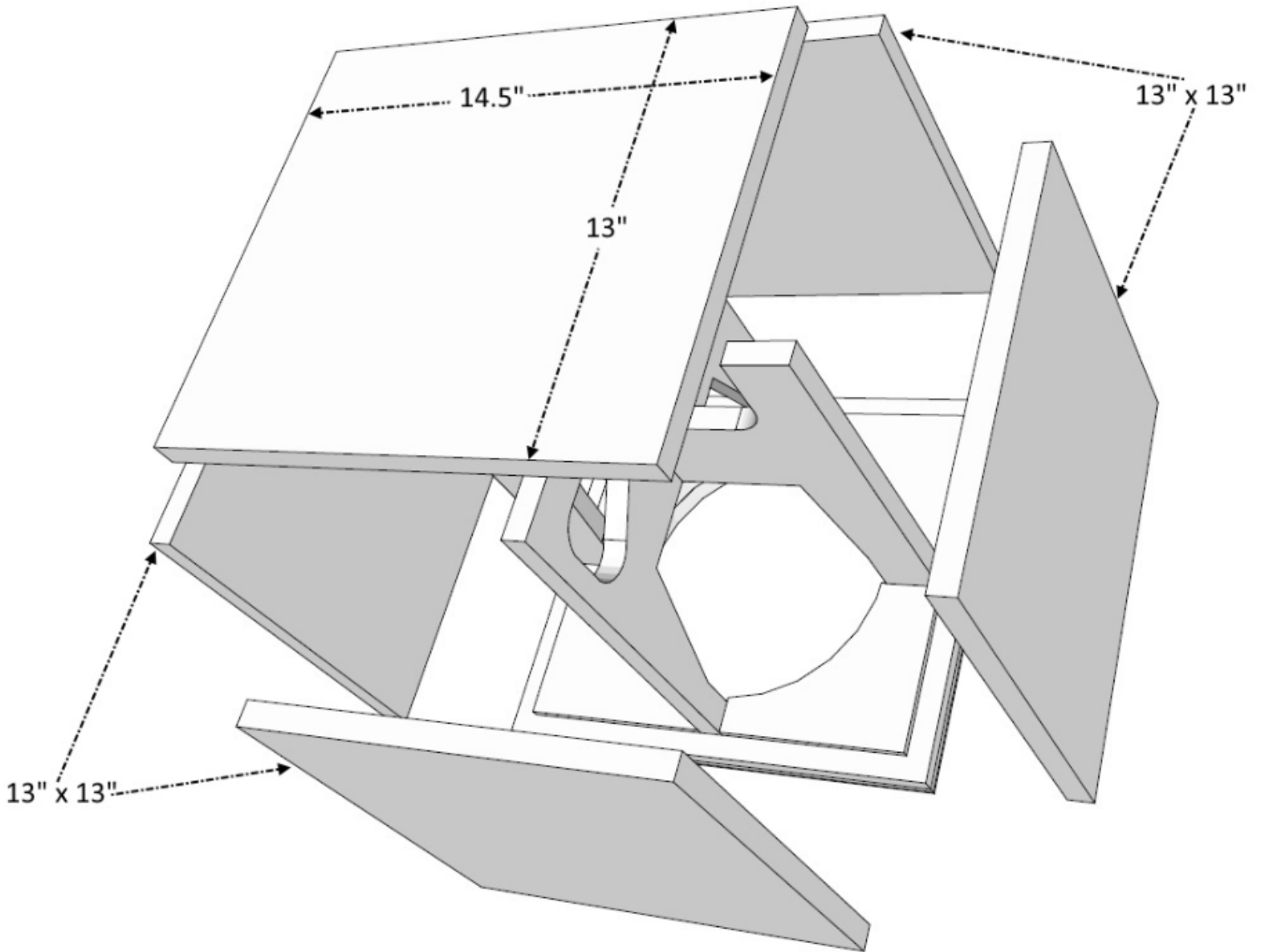

- 6) Glue all mating surfaces of two opposite side pieces and the baffle/brace assembly then assemble as shown. Make sure that the sides are centered on the baffle/brace assembly. Apply enough pressure to ensure glue is spread through each joint (some glue squeeze-out can be expected).

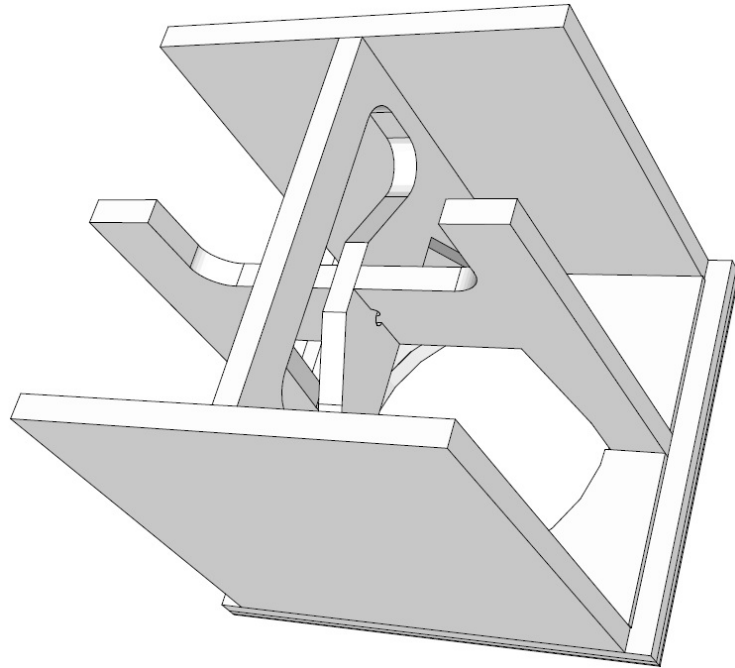

- 7) Glue all mating surfaces of two remaining side pieces and the baffle/brace assembly then assemble as shown. Make sure that the sides are centered on the baffle/brace assembly. Apply enough pressure to ensure glue is spread through each joint (some glue squeeze-out can be expected)

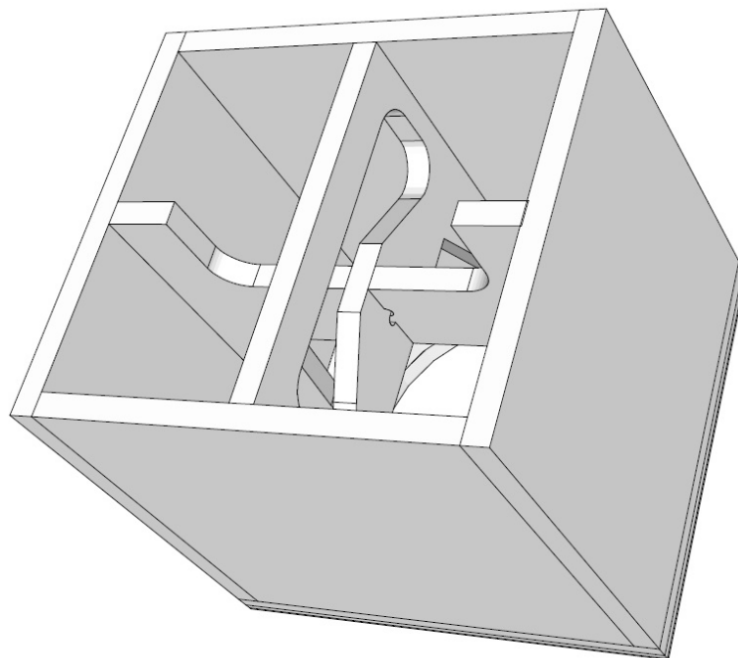

- 8) Finally, glue all mating surfaces of back panel and the rest of the enclosure then assemble as shown. Make sure that the back panel is centered on the enclosure. Apply enough pressure to ensure glue is spread through each joint (some glue squeeze-out can be expected). Clamp enclosure together so that even pressure is applied to all glued surfaces. After clamping, double check that all edges line up properly, this cannot be corrected once the glue dries. Using a damp rag or paper towel, wipe away any glue squeeze-out on the outside of the enclosure. Allow to dry according to the glue manufacturer's recommendations and remove clamps.

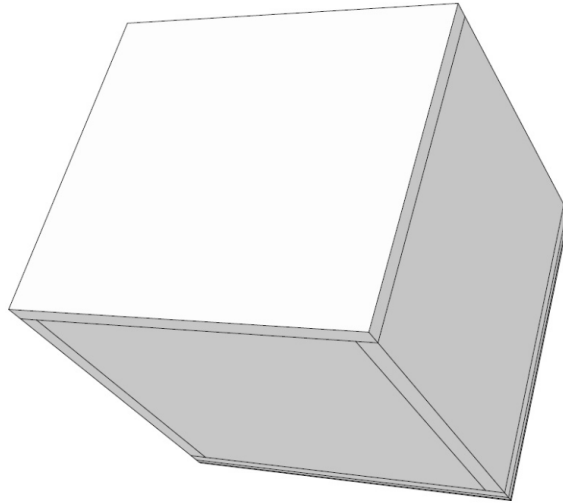

This completes the assembly of the 10" Subwoofer Starter kit. Sand the enclosure to a smooth surface on all edges and finish to your liking. Install your chosen subwoofer driver and enjoy.

