

- Cast Aluminum Frame
- Vented Cone Neck
- Glass Fibre Cone
- Ferrite Magnet
- Large Excursion



### SPECIFICATIONS

Transducer Size	4	in	
Impedance	8	$\Omega$	
Frequency Range <sup>1</sup>	60 - 15000	Hz	
Sensitivity <sup>2</sup> (2.83V   1W @ 1m)	85.5   85.5	dB	
Power Rating (IEC 268-5)	30	W	
Voice Coil Size	25.7	mm	
Air Gap   Winding Height	$H_{ag}$   $H_{vc}$	6   12	mm
Net Weight	0.906	kg	

### PARAMETERS <sup>3</sup>

Eff. Piston Area	$S_d$	55.4	cm <sup>2</sup>
DC Resistance	$R_e$	5.2	$\Omega$
Minimum Impedance	$Z_{min}$	5.8	$\Omega$
Inductance	$L_e$	0.23	mH
Resonance Frequency <sup>4</sup>	$F_s$	120	Hz
Mechanical Q Factor	$Q_{ms}$	2.17	-
Electrical Q Factor	$Q_{es}$	0.94	-
Total Q Factor	$Q_{ts}$	0.66	-
Moving Mass	$M_{ms}$	5.72	g
Compliance	$C_{ms}$	320	$\mu\text{m}/\text{N}$
Equivalent Volume	$V_{as}$	1.39	L
Motor Force Factor	$Bl$	4.85	Tm
Motor Efficiency	$\beta$	4.5	( $Bl$ ) <sup>2</sup> / $R_e$
Linear Excursion <sup>5</sup>	$X_{max}$	4.98	mm
Max Mechanical Excursion <sup>6</sup>	$X_{mech}$	7.5	mm

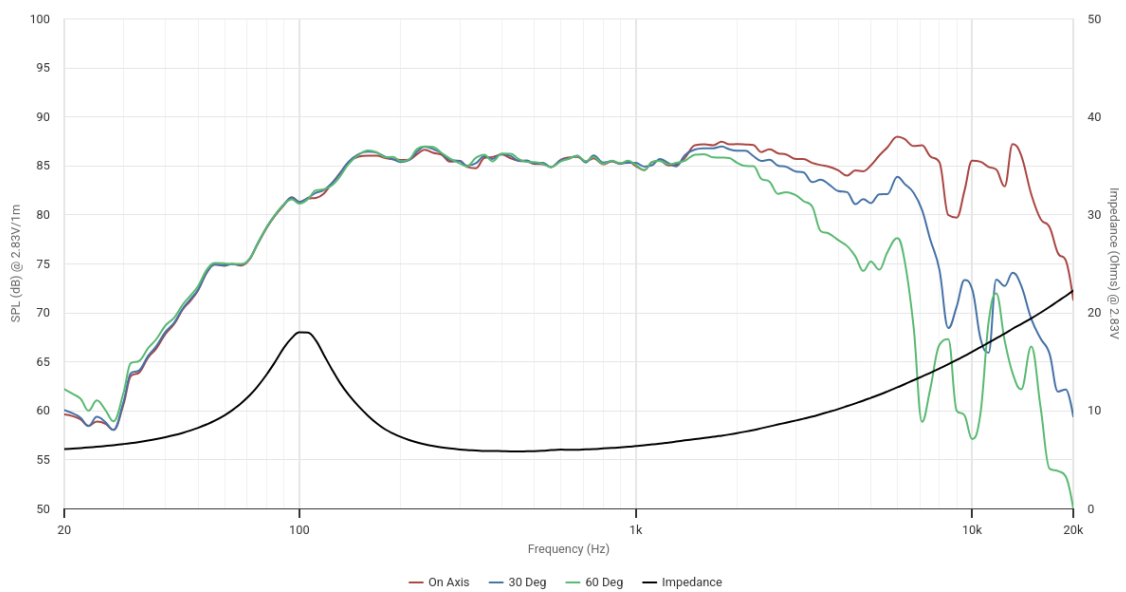
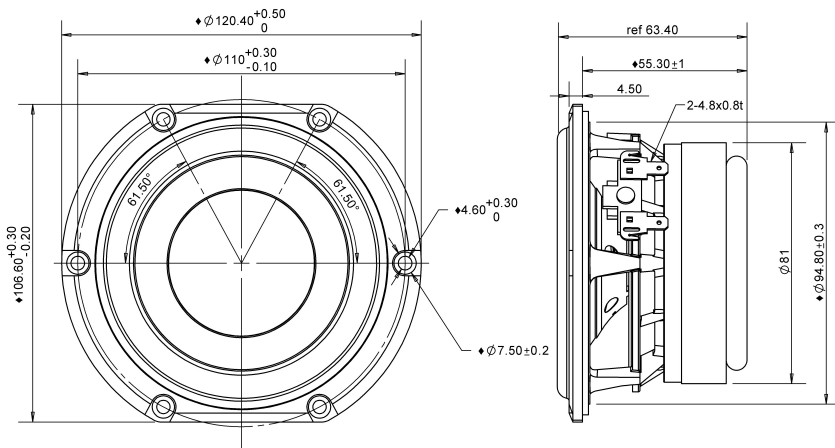

Details on this spec sheet are for reference only and should not be used for setting production limits. Specifications and product cosmetics are subject to change without notice. Peerless is a registered trademark of Tympany Enterprises. All measurements conducted in test lab at 25°C ±10°C, 50%RH ±10%. <sup>1</sup> Specified by Engineering as linear working range of transducer. <sup>2</sup> Measured at 2.83V at 1m and normalized to 1W with respect to nominal impedance. <sup>3</sup> Measured in Free Air without preconditioning, therefore subject to some deviation. <sup>4</sup> Impedance and  $F_s$  value measured under different conditions. <sup>5</sup> Equal/Overhung:  $(H_{vc} - H_{ag})/2 + H_{ag}/3$ . Underhung:  $(H_{ag} - H_{vc})/2 + H_{vc}/3$ . <sup>6</sup> Mechanically limited excursion (e.g. bottoming, spider crash).